

INTRODUCTION

Before installation and operation of the ERC Statohm IV, DC drive, read this instruction manual carefully. Installation should only be done by a fully qualified licensed electrician. The ERC Statohm IV, DC drive is only a portion of a complete drive system. Refer to the instruction manuals of the other components in the drive system for details about auxiliary equipment and the DC motor. This user's manual does not purport to cover all details or variations of DC drive installation, operation or maintenance.

CAUTION

Before MEGGER or DIELECTRIC testing the DC motor. Disconnect the DC motor from the Statohm IV control. Megger or dielectric testing will damage the semiconductors in the control.

Table of Contents

Pg. 3	Section 1) <u>Receiving & Storage</u>
Pg. 3	Section 1.1) Model Number Scheme
Pg. 3	Section 2) <u>Installation Location</u>
Pg. 3	Section 2.1) Operating Environment
Pg. 5	Section 3) <u>Jumper Settings</u>
Pg. 4	Jumper Setting Diagram
Pg. 5	Section 3.1) Field Current Jumpers
Pg. 5	Section 3.2) Armature Current Jumpers
Pg. 5	Section 3.3) Motor Feedback Jumper
Pg. 5	Section 3.4) DC Tach Voltage Jumpers
Pg. 5	Section 3.5) Field Regulation Jumpers
Pg. 5	Section 3.6) Acceleration and Deceleration Time Range Jumpers
Pg. 7	Section 4) <u>Wiring</u>
Pg. 6	Wire Size Tables
Pg. 6	Elementary Power Connection Diagram
Pg. 7	Section 4) Power and Control Circuit Wiring Introduction
Pg. 7	Section 4.1) AC Power Connections
Pg. 7	Section 4.2) Grounding
Pg. 7	Section 4.3) Phase Sequence Test
Pg. 7	Section 4.3A) Fuse Replacement
Pg. 7	Section 4.4) Armature Connections
Pg. 8	Section 4.5) Field Connections
Pg. 8	Section 4.5A) Field Disable
Pg. 9	Section 4.6) PC, Pre-Operational Conditions (i.e. Enable Drive)
Pg. 9	Section 4.7) Speed Reference & Reverse
Pg. 10	Section 4.8) Jog
Pg. 10	Section 4.9) Start & Stop (i.e. Run & Stop)
Pg. 10	Section 4.10) Emergency Stop (E.Stop)
Pg. 10	Section 4.11) DC Tach generator Feedback
Pg. 11	Section 4.12) Meter Dimensions
Pg. 12	Section 4.13) Speed Meter Wiring and Calibration
Pg. 13	Section 4.14) Armature Ammeter Wiring and Calibration
Pg. 14	Section 4.15) Field Ammeter Wiring and Calibration

ERC Statohm IV (Table of Contents)

Pg. 15	Section 5) <u>Operation and Adjustment</u>
Pg. 15	Section 5.1) Check prior to operation
Pg. 15	Section 5.2) Pre-Operation Voltage Checks
Pg. 15	Section 5.3) Test Run
Pg. 15	Section 5.4) Jog Speed & Ramp Adjustment
Pg. 16	Section 5.5) Emergency Stop (E. Stop)
Pg. 16	Section 5.6) ZD, Zero motor rotation Detection relay and signal light adjustment
Pg. 16	Section 5.7) Zero Speed Adjust (12 SCR Regenerative Drives Only)
Pg. 17	Section 5.8) Zero Speed Hysteresis Adjustment (12 SCR Regenerative Drives Only)
Pg. 17	Section 5.9) Maximum Speed Adjustment for Armature Feedback
Pg. 17	Section 10) Maximum Speed Adjustment for DC Tach Feedback
Pg. 18	Section 5.11) Field Amperage Adjustment
Pg. 18	Section 5.11A) Field Weakening Adjustment (Tach Feedback Only)
Pg. 18	Section 5.11B) Field Economy
Pg. 18	Section 5.11C) Field Disable
Pg. 18	Section 5.11E) Field Loss
Pg. 18	Section 5.11F) Field Voltage Regulation
Pg. 19	Section 5.12) Armature Current Calibration
Pg. 19	Section 5.12A) Current Limit Adjustment
Pg. 19	Section 5.12B) Forward and Reverse Current Limit Adjustment
Pg. 19	Section 5.12C) One Minute Timed Overload Shut-off Adjustment
Pg. 19	Section 5.12D) Instantaneous Overload Current Shut-off Adjustment
Pg. 20	Section 5.13) Acceleration & Declaration Time Adjustment
Pg. 20	Section 5.14) Speed Overshoot and Stability Adjustment Overview
Pg. 20	Section 5.14A) Speed Overshoot Adjustment (i.e. Speed Response)
Pg. 20	Section 5.14B) Speed Stability Adjustment (i.e. Speed Gain)
Pg. 21	Section 5.15) ASR Feedback Loop Adjustment (i.e. Speed PID)
Pg. 21	Section 5.16) Current Gain Loop Adjustment (i.e. Current PID)
Pg. 22	Section 5.17) Master Slave Operation
Pg. 25	Section 6) <u>Troubleshooting</u>
Pg. 25	Section 6.1) Phase Load Balancing
Pg. 27	Section 6.2) Motor won't start but non of the signal lights are on.
Pg. 27	Section 6.3) Motor Speed Runaway
Pg. 28	Section 6.4) Fuses blow immediately after start and the "OC signal lights
Pg. 29	Section 6.5) Unstable Speed
Pg. 30	Section 6.6) Motor will not go to full speed
Pg. 30	Section 6.7) Excessive overshoot and undershoot
Pg. 30	Section 6.8) Overload fault "OL" signal light
Pg. 31	Section 6.9) The ES, OH, VL signal lights are on and can not be reset
Pg. 31	Section 6.10) Signal lights R and PC are on F,AP, ZD flash and relays buzz.
Pg. 31	Section 6.11) Field loss is detected.
Pg. 32	Section 6.12A) Armature current is too high at low speed and normal load.
Pg. 32	Section 6.12B) During acceleration or heavy load the field is too low.
Pg. 33	Section 6.13) PH Light is on
Pg. 33	Section 6.14) The F light is dimly lite but field loss is not detected
Pg. 33A	Section 6.15) Regulator card connections
Pg. 33A	Section 6.16) Utilty company transfer switch problems (PH light disable)
	<u>ATTACHMENTS</u>
Pg. 34	"S" Model Physical Diagram
Pg. 35	"M2" Model Physical Diagram
Pg. 36	"M3" Model Physical Diagram
Pg. 37	"L1" Model Physical Diagram
Pg. 37A	"L2" Model Physical Diagram
Pg. 38	IFC 1084 Card
Pg. 38	41FS Auxiliary Field Supply
Pg. 39	Synchronization Card 1058C
Pg. 40	Oscilloscopes
Pg. 42	Regulator Card Control Block Diagram #9044
Pg. 43	Regulator Card Block Diagram # 9042-1
Pg. 44	Regulator Card Block Diagram # 9042-2
Pg. 45	Regulator Card Block Diagram # 9042-3
Pg. 46	Elementary Circuit Diagrams
Pg. 47	Terminal Table (for Regulator Card)
Pg. 48	Regulator Card 1059A Physical Diagram
Pg. 49	Regulator Card Tables (for Pots, Jumpers, Signal Lights and Test Points)
Pg. 50	Common Specifications
Pg. 51	Alphabetical Index

Section 1 Receiving & Storage

When you receive the ERC Statohm IV DC drive, avoid shock or vibration when unloading and transporting the unit. This can damage the semiconductors or other components. Immediately upon receipt, inspect the unit for the following;

- Check to be certain the unit is clean of packing materials.
- Check for damage incurred during shipment, dents, scratches, ect.
- Inspect mechanical the parts, loose screws, terminals, hinges, ect.
- Inspect the circuit cards, damaged, loose or shorted electronic components or connections.
- If you find damage do not connect power to it. The unit must be replaced or repaired. Connecting power could result in fire or further damage and void the warranty.
- Promptly report damage or problems you found during inspection to Electric Regulator Corp., Telephone (760) 438-7873, Fax (760) 438-0437
- Store the ERC Statohm IV control in a clean dry place, in the package it was shipped. Avoid storing the unit in a location with high temperatures, humidity, dust or corrosive gases. Outdoor storage is not recommended.

Section 1.1) Model Number Scheme

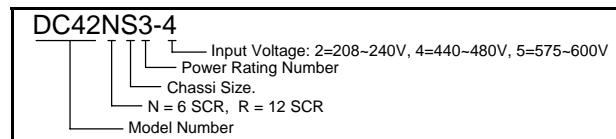

Model Ampere and Horsepower Ratings

Model Number	42NS1-*	42RS1-*	42NS2-*	42RS2-*	42NS3-*	42RS3-*	42NS4-*	42RS4-*	42NM2-*	42RM2-*	42NM3-*	42RM3-*	42NL1-*	42RL1-*	42NL2-*	42RL2-*	42NL4-*	42NL5-*	42NL7-*
Max., Current	37A	70A	110A	180A	400A	550A	720A	910A	1100A	1400A	1800A	---	---	---	---	---	---	---	---
Input 208~240V, Arm 240V	7 HP	15 HP	25 HP	45 HP	100 HP	125 HP	200 HP	250 HP	300 HP	---	---	---	---	---	---	---	---	---	---
Input 440~480V, Arm 500V	14 HP	30 HP	50 HP	90 HP	200 HP	250 HP	400 HP	500 HP	600 HP	750 HP	1,000 HP	---	---	---	---	---	---	---	---
Input 575~600V, Arm 600V	---	36 HP	60 HP	108 HP	240 HP	300 HP	480 HP	600 HP	720 HP	900 HP	1,200 HP	---	---	---	---	---	---	---	---

Section 2 Installation Location

Section 2.1 Operating Environment

The ERC Statohm IV control should be located in a operating environment that meets the following conditions.

- Ambient Temperature between 14° to 104° Fahrenheit (-10° to 40° Celsius).
- Relative Humidity Avoid locations exceeding RH 90%.
- Condensation Do not locate the unit where condensation occurs.
- Corrosion Avoid locations with corrosive gases or liquids; example: ocean air.
- Contamination Avoid locations subject to dust or iron particles.
- Hazardous Gases & Liquids Do not locate the unit were it is subject to combustible or flammable gases or liquids.
- Ventilation Mount the unit in a lengthwise vertical position to ensure proper cooling ventilation. Provide not less than 5 inches (125 mm) of clear space on all sides of the unit. If the unit is in a sealed enclosure, provide adequate ventilation for air flow from top to bottom.
- Shock & Vibration Avoid mounting the unit in a location subject to shock or vibration.

REGULATOR CARD 1059D and earlier depicted
 REGULATOR CARD 1059F eliminated jumpers 2,3,6, FV, FI and added jumpers 11 and 12

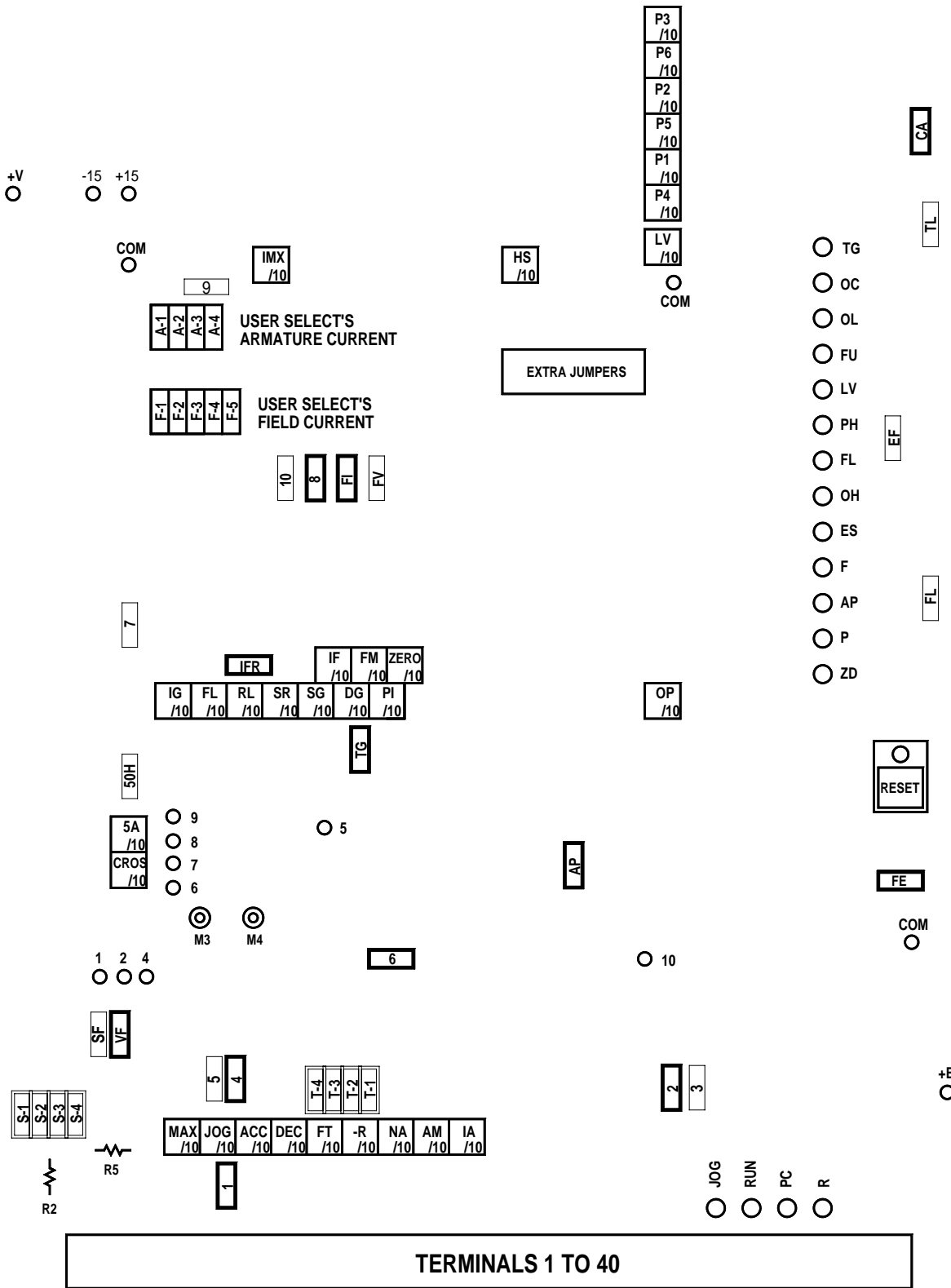

JUMPER ON JUMPER OFF
 User Selects

Armature Feedback Jumper Settings

JUMPERS ON: AP, CA, FE, FI, IFR, TG, VF, 1, 2, 4, 6, 8
 Regulator card 1059F does not require jumpers 2 and 6 for armature feedback

Section 3 Jumper Setting Tables

The jumper settings must be made prior to applying power. Complete the blanks below to determine the jumper settings for your application. Consult the jumper tables below or “Master Jumper Table” to the left.

- Armature Voltage _____ V_{DC}
- Field Current _____ A.
- Feedback _____ (Arm or Tach)
- Field Regulation _____ (constant current, field weakening, permanent magnet) (Field Economy enabled or disabled)
- Armature Current Limit _____ A.
- Acceleration Time _____ Sec.
- Deceleration Time _____ Sec.

Jumper Tables

3.1 Field Current

“S1” Model Current Range	“S2, S3 & S4” Models Current Range	“M2 & M3” Models Current Range	M4 Model Current Range	“L1 & L2” Models Current Range	Jumper Settings
4.3 ~ 7.1	6A ~ 10A	10A ~ 17A	NA	15A ~ 25A	F1 - On F2, F3, F4, F5 - Off
2.1 ~ 4.3	3A ~ 6A	5A ~ 10A	NA	7.5A ~ 15A	F2 - On F1, F3, F4, F5 - Off
1.4 ~ 2.1	2A ~ 3A	3.3A ~ 5A	NA	5A ~ 7.5A	F3 - On F1, F2, F4, F5 - Off
0.7 ~ 1.4	1A ~ 2A	1.7A ~ 3.3A	NA	2A ~ 2.5A	F4 - On F1, F2, F3, F5 - Off
0.6 ~ 1.2	0.8A ~ 1A	1.3A ~ 1.7A	NA	1.3A ~ 2A	F5 - On F1, F2, F3, F4 - Off

3.2 Armature Current (see section 5.12 for Armature Current Calibration)

“S1” Model Current Range	“S2” Model Current Range	“S3” & “S4” Model Current Range	“M2” & “M3” Model Current Range	“L1 & L2” Model Current Range	Jumper Settings
14 ~ 23	48A ~ 81A	183A ~ 300A	366A ~ 600A	730A ~ 1,200A	A1, A2, A3, A4 - On
12 ~ 20	35A ~ 58A	161A ~ 269A	322A ~ 538A	640A ~ 1,100A	A1, A2, A3 - On A4 - Off
8.6 ~ 14	25A ~ 42A	115A ~ 192A	230A ~ 384A	460A ~ 770A	A1, A3 - On A2, A4 - Off
6 ~ 10	18A ~ 30A	83A ~ 139A	166A ~ 277A	330A ~ 560A	A1 - On A2, A3, A4 - Off
4.5 ~ 7.5	14A ~ 23A	60A ~ 100A	120A ~ 200A	240A ~ 400A	A2 - On A1, A3, A4 - Off
3.5 ~ 5.9	11A ~ 19A	46A ~ 78A	93A ~ 150A	190A ~ 300A	A3 - On A1, A2, A4 - Off
2.8 ~ 4.7A	7A ~ 12A	38A ~ 62.5A	75A ~ 125A	150A ~ 250A	A4 - On A1, A2, A3 - Off

3.3 Motor Feedback

Feedback	Jumper Settings
Armature	VF, TG - On SF, TL - Off
DC Tachometer Generator	SF, TG, TL - On VF - Off

3.4 DC Tach Generator Voltage

Example: DC tach is 50V_{DC}/1000 rpm and DC motor’s maximum speed is 2150 rpm 2.15 x 50 = 107.5 Volts select voltage range 88v~127V., jumpers S2- On / S1, S3, S4 - Off

Standard Setting (R2 & R5 are 220kΩ resistors)	Special Setting (R2 & R5 are zero ohm jumpers)	Jumper Settings
41V ~ 60V	27V ~ 41V	S1, S2, S3, S4 - Off
60V ~ 88V	41V ~ 60V	S1 - On S2, S3, S4 - Off
88V ~ 127V	60V ~ 88V	S2 - On S1, S3, S4 - Off
127V ~ 172V	88V ~ 127V	S3 - On S1, S2, S4 - Off
172V ~ 250V	127V ~ 172V	S4 - On S1, S2, S3 - Off

3.5 Field Regulation

Field Operation	Jumper Settings
Constant Field (default)	J8 - On J7 - Off
Field Weakening (Tach Feedback Only)	J7, J8 - On
Field Economy	Enable: FE - Off (default) Disable: FE - On
Disabling Field	FL- On Don’t connect power to F+ and F-

3.6 Acceleration & Deceleration Time Range

Time Range	Jumper Setting
0.7 ~ 6 Sec.	T1 - On T2, T3, T4 - Off
3 ~ 20 Sec. (default)	T2 - On T1, T3, T4 - Off
7 ~ 60 Sec.	T3 - On T1, T2, T4 - Off
14 ~ 120 Sec.	T3, T4 - On T1, T2 - Off

Wire Size Tables

230 V_{AC} 3 Phase 60 Hz Input

HP	Full Load AC Amps	Minimum Wire Size for 40 ft length	Circuit Breaker AC Amps at 250V _{AC}
5	17	12 AWG	25
7.5	25	10 AWG	30
10	32	8 AWG	40
15	49	6 AWG	70
20	63	4 AWG	90
25	79	3 AWG	100
30	93	1 AWG	125
40	124	00 AWG	175
50	156	000 AWG	200
60	184	0000 AWG	225
75	229	300 MCM	300
100	300	500 MCM	400
125	380	(2) 250 MCM	500
150	450	(2) 350 MCM	600

460 V_{AC} 3 Phase 60 Hz Input

HP	Full Load AC Amps	Minimum Wire Size for 40 ft length	Circuit Breaker AC Amps at 600V _{AC}
5	8.6	14 AWG	10
7.5	11	14 AWG	15
10	13.5	12 AWG	20
15	21	10 AWG	30
20	27	8 AWG	35
25	34	8 AWG	40
30	40	6 AWG	50
40	54	4 AWG	70
50	67	4 AWG	90
60	80	3 AWG	100
75	99	1 AWG	125
100	133	00 AWG	175
125	167	0000 AWG	225
150	202	250 MCM	300
200	266	(2) 000 AWG	400
250	375	(2) 250 MCM	500

240 V_{DC} Armature

HP	Full Load DC Amps	Minimum Wire Size for 40 ft length	DC Fuse Amps (if used)
5	19	10 AWG	25
7.5	28	8 AWG	40
10	36	6 AWG	50
15	54	4 AWG	70
20	70	2 AWG	100
25	87	1 AWG	150
30	105	0 AWG	150
40	139	0000 AWG	200
50	173	250 MCM	250
60	205	300 MCM	300
75	254	500 MCM	400
100	337	(2) 250 MCM	600
125	325	(2) 350 MCM	600
150	504	(2) 500 MCM	800

500 V_{DC} Armature

HP	Full Load DC Amps	Minimum Wire Size for 40 ft length	DC Fuse Amps (if used)
5	10	12 AWG	15
7.5	12	12 AWG	20
10	15	10 AWG	25
15	23	8 AWG	35
20	30	8 AWG	45
25	38	6 AWG	60
30	45	4 AWG	70
40	60	3 AWG	100
50	75	2 AWG	150
60	90	1 AWG	150
75	110	00 AWG	200
100	148	0000 AWG	250
125	185	300 MCM	300
150	218	(2) 000 AWG	400
200	295	(2) 250 MCM	600
250	408	(2) 350 MCM	600

150 V_{DC} Field

Wire Size for 40 ft Length

5 - 75 H.P. : 14 AWG
100 - 200 H.P. : 12 AWG

300 V_{DC} Field

Wire Size for 40 ft Length

5 - 75 H.P. : 14 AWG
100 - 200 H.P. : 14 AWG

Elementary Power Connection Diagram

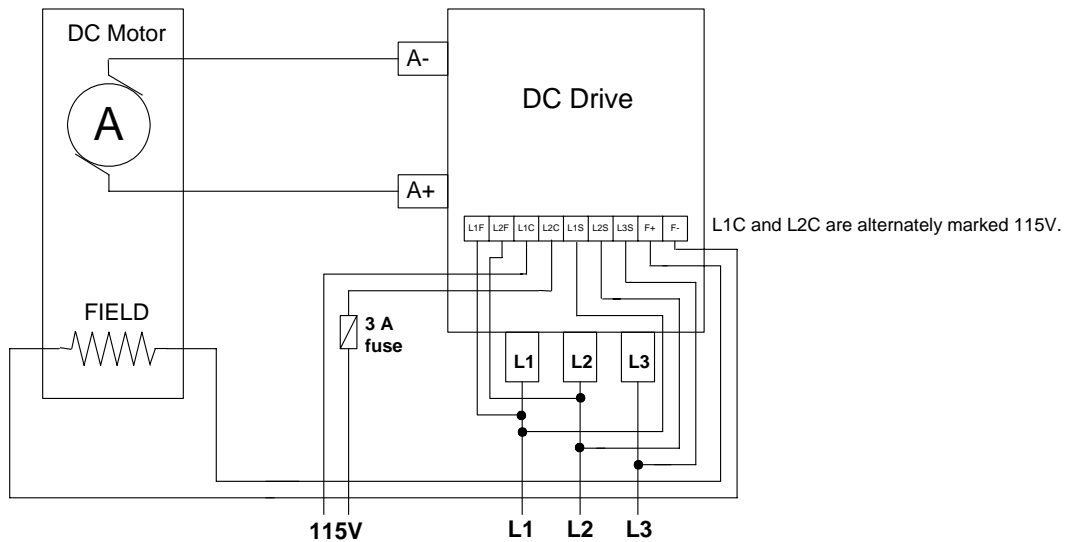

Section 4 Power & Control Circuit Wiring Introduction

The ERC Statohm IV is only one part of an entire drive system. The drive system engineer should supply a wire diagram and/or wire connection net list (i.e. net list) for the drive system's control panel, switch panel, DC motor and other auxiliary equipment.

For easier installation we recommend the power circuit should be installed first and the control circuitry second.

WARNING

Separate over current protection is required by the national electric code. The user is responsible for conforming with the national electric codes and all applicable local codes which govern such practices such as wiring protection, grounding, disconnects and other current protection.

Power Circuit Wiring

NOTICE

Make all power circuit connections in accordance with the drive system engineer's wire diagram or the elementary wire diagrams provided in this manual. The power circuit includes terminals L1, L2, L3, L1F, L2F, L1S, L2S, L3S, A+, A-, F+, F- and 115V.

4.1 AC Power Connections

- See on the Wire Size Tables on page 6 and Elementary Wiring Diagram below.
- Connect the three phase AC power to the buss terminals marked: L1, L2, L3 and to terminals L1S, L2S, L3S that supply the SYNC card and to L1F, L2F that supply the field.
- Connect the single phase 110 ~ 120 V_{AC} power to terminal block positions "115V" (alternately marked L1C and L2C).

4.2 Ground in accordance with national and local electrical codes and regulations.

4.3 Phase Sequence Test

The Statohm IV PH signal light indicates if the phase of L1, L2 and L3 are in the same sequence as L1S, L2S and L3S.

Turn on the AC power, if the PH light is off the phase sequence is correct. If the PH light is on, the phase sequence is wrong. To correct the phase sequence. Turn off the power. Check with an Ohm meter the sequence of L1, L2 and L3 are in the same sequence as L1S, L2S and L3S and power test again. If this fails, change the sequence of L1 and L2 and test again. If this fails, check the plugs connections from L1S, L2S and L3S to the synchronization card (i.e. SYNC card and test again. Additional phase sequence tests are covered in section 6.13 Problem: PH Light is on.

4.3A Fuse Replacement

When replacing fuses on the "M3" and "L" model drives, keep the fuse relay # G310000 MS3V 2-5 attached to the side of the fuse. The replacement fuse doesn't include the fuse relay. The fuse relay can be used again. Note: "S" models and the "M2" model don't have fuse relays.

If you can not get replacement fuses from your local electrical supply. Replacement fuses are available from Electric Regulator.

4.4 Armature Connections

- See the motor data plate for the armature’s amp rating. Then select the wire size from the Wire Size Table at the beginning of section 4.
- Connect the motor’s armature to the power busses marked A+ and A- .
- Current Range is selected from jumper the table below.
- For instructions about adjusting the Current Limit, see section 5.12

“S1” Model Current Range	“S2” Model Current Range	“S3 & S4” Model Current Range	“M2 & M3” Model Current Range	“L1 & L2” Model Current Range	Jumper Settings
14 ~ 23	48A ~ 81A	183A ~ 300A	366A ~ 600A	730A ~ 1,200A	A1, A2, A3, A4 - On
12 ~ 20	35A ~ 58A	161A ~ 269A	322A ~ 538A	640A ~ 1,100A	A1, A2, A3 - On A4 - Off
8.6 ~ 14	25A ~ 42A	115A ~ 192A	230A ~ 384A	460A ~ 770A	A1, A3 - On A2, A4 - Off
6 ~ 10	18A ~ 30A	83A ~ 139A	166A ~ 277A	330A ~ 560A	A1 - On A2, A3, A4 - Off
4.5 ~ 7.5	14A ~ 23A	60A ~ 100A	120A ~ 200A	240A ~ 400A	A2 - On A1, A3, A4 - Off
3.5 ~ 5.9	11A ~ 19A	46A ~ 78A	93A ~ 150A	190A ~ 300A	A3 - On A1, A2, A4 - Off
2.8 ~ 4.7A	7A ~ 12A	38A ~ 62.5A	75A ~ 125A	150A ~ 250A	A4 - On A1, A2, A3 - Off

4.5 Field Connections

- See the motor’s data plate for the field’s amp rating. Then select the wire size from the Wire Size Table at the beginning of section 4. We also strongly recommend reading page 41.
- The polarity of the field determines the motor’s direction of rotation. Connect the motor field wires F1 and F2 to the terminal strip points F+ and F- according to the required direction of rotation. Note: The American industry standard for determining if a motor’s rotation is clockwise or counterclockwise is to view the motor from the commutator end. The commutator end of a standard DC motor is the opposite end from the drive shaft.
- The field current is selected by setting the appropriate jumper in the table below. See motor’s name plate for the motor’s field current. Note: The field current is limited by the input voltage. The field voltage will not 71% of the input voltage. Example: With 460V connected to L1F and L2F, the field voltage will not exceed 327 volts.

“S1” Model Current Range	“S2 & S4” Models Current Range	“M2 & M3” Models Current Range	“L1 & L2” Models Current Range	Jumper Settings
4.3 ~ 7.1	6A ~ 10A	10A ~ 17A	15A ~ 25A	F1 - On F2, F3, F4, F5 - Off
2.1 ~ 4.3	3A ~ 6A	5A ~ 10A	7.5A ~ 15A	F2 - On F1, F3, F4, F5 - Off
1.4 ~ 2.1	2A ~ 3A	3.3A ~ 5A	5A ~ 7.5A	F3 - On F1, F2, F4, F5 - Off
0.7 ~ 1.4	1A ~ 2A	1.7A ~ 3.3A	2A ~ 2.5A	F4 - On F1, F2, F3, F5 - Off
0.6 ~ 1.2	0.8A ~ 1A	1.3A ~ 1.7A	1.3A ~ 2A	F5 - On F1, F2, F3, F4 - Off

4.5A Field Disable

The field is disabled when the motor has a permanent magnet field or series field and armature. To disable the field loss detection circuit, put the jumper FL on and don’t connect power to L1F and L2F. Note: The yellow “F” light will remain on when the field is disabled.

Field Weakening See Section 5.11A

Control Circuit Wiring

Elementary Control Circuit Functions

- Start/Run (terminal 34)
- Emergency Stop (terminal 40)
- Speed Reference (terminals 7,8 and 9)
- Reverse has two options (12 SCR drives only)
 - Option 1) Terminal 37.
 - Option 2) Speed Reference Voltage Polarity
- Jog, if used (terminal 33)
- PC, Enable Drive (terminal 36)
- DC Tach Feedback, if used (terminals 1 and 2)

NOTICE

Make all control circuit connections in accordance with the drive system engineer’s wire diagram or the elementary wire diagrams provided in this manual if applicable. The control circuit terminals 1 through 40 are located on the regulator card.

WARNING

Electrical noise pickup on the control circuit wiring can cause erratic operation.

- Never use solid wire.
- Use shielded wires or twisted wires for the control circuit. Connect shielding to common terminal of each circuit.
- Run the control circuit wires in a separate duct or conduit. Maintain a space of 2 inches (50 mm) or more from the general power circuit.

4.6 PC (Enable Drive)

The PC terminal number 36, enables the drive before start. This is a safety to detect when external Pre-operational Conditions (PC) are engaged before the DC drive is able to start. Example: A safety door has a micro switch connected to terminals 36 (PC) and 35 (COM). When the door is open the micro switch is open. When the door is closed PC is engaged. PC must remain closed during motor operation. PC should not be used to start and stop the motor. If your application doesn’t require PC, connect a jumper wire from 35 to 36.

4.7 Speed Reference & Reverse

Speed Reference has two options.

Option 1) The factory default setting is 0 to 8 volts with the power supplied by the regulator card. A potentiometer (typically a 500Ω pot) is connected to terminals 7, 8 and 9. The pot’s wiper is connected to terminal 8 (Speed Reference). If you have a 12 SCR drive, **Reverse** is activated by connecting terminal 37 (Reverse) to 35 (Com). This changes the polarity of the speed reference voltage (terminals 7 and 9) and the motor changes direction.

Option 2) If an external speed reference power supply is used. You have the choice of ± 8V or ± 10V by setting jumper JP-1, see the jumper table below. Connect the speed reference signal to terminals 8 and 9. The motor is reversed by changing the polarity of the speed reference voltage.

Jumper: JP-1	0~8V or ± 8V speed reference voltage Jumper ON (default) ± 8V requires external power supply
	0~10V or ± 10V speed reference voltage Jumper OFF, External 10V or ± 10V power supply required

4.8 Jog

Jog will run up to 20% of full speed. The FT pot adjusts Jog’s acceleration time equal to or faster than ACC setting. Important note: FT also adjusts E. Stop’s deceleration time. See section 4.10 option 2. The user must decided the priority when making this setting. The control circuit should be designed so that Jog and Start (Run) are not on simultaneously. They should only be on alternately.

4.9 Start/Run and Stop

To start the drive close terminals 34 (Run) to 35 (Com). For normal stop with deceleration time controlled by the Deceleration pot, open terminals 34 and 35.

Note: Don’t open PC to stop the motor, see section 4.6

4.10 Emergency Stop (E.Stop)

Emergency Stop has two options.

Option 1) Freewheeling stop is the factory default setting. The motor is allowed to coast to a stop and the regulator card power is switched off.

Option 2) Controlled deceleration stop To enable controlled E Stop, set the EF jumper ON and make jumper connections from terminals 21 to 35 and 23 to 36. The E. Stop deceleration time can be set to equal to or less than the DEC pot setting. The “FT” pot adjusts the E. Stop deceleration time. Note: FT also equally adjusts Jog’s acceleration time. (See section 4.8) Proper adjustment of the OP pot is required for a complete stop (see section 5.5A). The OP pot sets the point when the regulator card power is switched off. Setting the OP pot too low will cause the ZD relay to buzz

Emergency Stop mode	Jumper Setting
Power Off Uncontrolled Coast to Stop	EF - Off
Controlled Deceleration Stop	Jumper EF - On and ZD relay terminals are connected 21 to 35 and 23 to 36. See diagram to the right

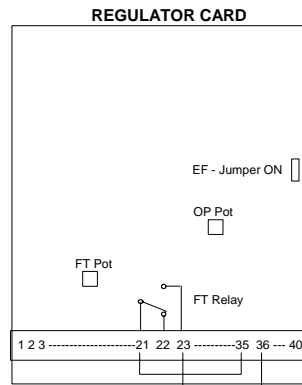

4.11 DC Tach generator Feedback

The factory default setting is armature feedback (i.e.. Voltage Feedback, VF). If tach feedback (i.e.. Speed Feedback, SF) is used. Move the jumper on VF to SF. Next calculate the maximum tach voltage. Example, the tach is 50V per 1000 rpm and the base speed of the motor is 1750 rpm. The maximum voltage will be 87.5V (1.75 x 50). The table shows jumper S1 (60~88V) would be appropriate. The speed will not to exceed 88 volts or 1760 RPM. If field weakening is used and 2200 rpm is required. Then calculate 2.2 x 50=110, jumper S2 (88~127V) is in this range. This range will permit the speed to go up to but not exceed 2540 RPM ((127/50)1000=2540).

DC Tach Generator		Jumper Settings
R2 and R5 are 220k ohms (standard setting)	R2 and R5 are zero ohm jumpers. (special setting)	
41V ~ 60V	27V ~ 41V	S1, S2, S3, S4 - Off
60V ~ 88V	41V ~ 60V	S1 - On S2, S3, S4 - Off
88V ~ 127V	60V ~ 88V	S2 - On S1, S3, S4 - Off
127V ~ 172V	88V ~ 127V	S3 - On S1, S2, S4 - Off
172V ~ 250V	127V ~ 172V	S4 - On S1, S2, S3 - Off

Section 4.12 Meter Dimensions

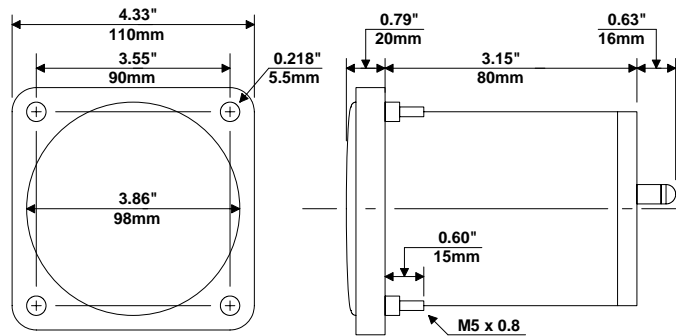

Meter Dimensions

Meters are an optional accessories available from Electric Regulator.

Meters are stocked in the following scales.

Scale of face plate	Input
0 to 50 Amps	0 to 2 volts
0 to 100 Amps	0 to 2 volts
0 to 200 Amps	0 to 2 volts
0 to 400 Amps	0 to 2 volts
-100, 0, +100 Amps, Center Zero	0 to 2 volts
-200, 0, +200 Amps, Center Zero	0 to 2 volts
0 to 100%	0 to 2 volts
0 to 150%	0 to 2 volts
-150%, 0, +150%, Center Zero	0 to 2 volts
0 to 2000 RPM	0 to 1 mA
0 to 100%	0 to 1 mA
-100%, 0, +100%, Center Zero	0 to 1 mA
0 to 600 Volts	0 to 1 mA
0 to 300 Volts	0 to 1 mA

The Statohm IV has meter outputs for Armature current, Field current and Motor Speed.

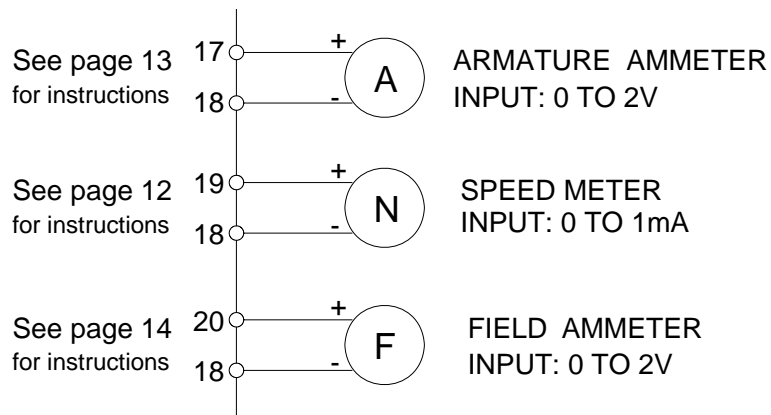

Section 4.13) Speed Meter Wiring and Calibration

Selecting a meter

- The speed meter is an ammeter with a 0 to 1 mA input (meters are available from ERC).
- The application determines the units and the scale of the meter's face plate.
For example, units RPM, scale 2000. For one direction rotation, left is zero and full clockwise is 2000 RPM. If you are reversing the motor, a meter with a center zero with right and left scales is required.

Jumper and Potentiometer Settings

Before calibrating the ammeter make all final jumper settings and pot adjustments.

- Make final settings to jumpers A1, A2, A3 and A4.
- Set Jumpers, SF-on, VF-off and user selects JP-7.
- Make final adjustments to potentiometers (pots), MAX and CROS.
- If any of these settings are changed after calibrating the speed meter, recalibration of the speed meter is required.

How to calibrate the speed meter.

- An independent speed measurement for reference is required to calibrate the speed meter. You can improvise by using a voltmeter to measure the armature voltage or DC tach voltage. Then use the voltage to calculate the speed.
- The NA pot calibrates the speed meter
- Run the motor at a level speed and adjust the NA pot until the speed meter equals the independent speed measurement.

The speed meter circuit is a current regulator circuit, the NA pot sets the current limit.

Example: The meter has a 0 to 2000 RPM face plate, the input is 1 mA = 2000 RPM (100%). The motor's base speed is 1750 RPM. The speed meter is calibrated by running the motor at base speed and adjusting the NA pot until the meter reads 1750 RPM. The current limit is set to 0.875 mA (1750 RPM = 0.875 mA). If changes are made to extend the speed of the motor to 1900 RPM by using field weakening. If the speed meter is not recalibrated. The speed meter will read 1750 RPM when the motor is actually running 1900 RPM. Creating a 8.5% error over the entire meter's range. The speed meter must be recalibrated by adjusting the NA pot to read 1900 RPM at full speed (1900RPM = 0.95 mA).

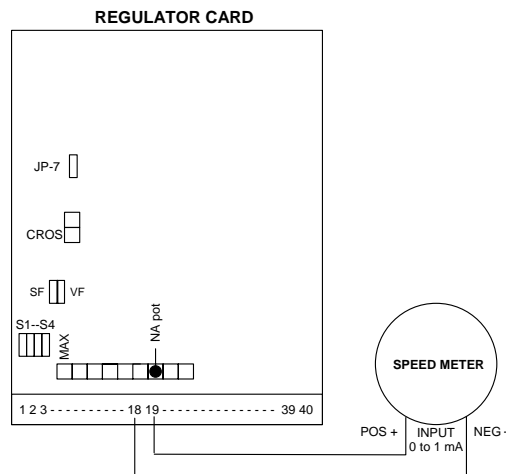

Section 4.14) Armature Ammeter Wiring and Calibration

Selecting a meter.

- The armature ammeter is a voltmeter with a 0 to 2 volt input (meters are available from ERC).
- The motor's rating and application determines the scale of the meter's face plate.
For example, a 0 to 2 volt meter with 100 Amp scale face plate. For one direction operation, left is zero and full clockwise is 100A. If you are reversing the motor, a center zero with left and right scales is required.

Jumper and Potentiometer Settings

Before calibrating the ammeter make all final jumper settings and pot adjustments.

- Make final setting of jumpers A1, A2, A3 and A4.
- Set JP2 - on, JP3 - off.
- Make final adjustment of potentiometer (pot), IMX.
- If any of these settings are changed after calibrating the ammeter, recalibration of the ammeter is required.

How to calibrate the ammeter.

- An independent ammeter for reference is required to calibrate the ammeter.
- The AM pot calibrates the ammeter
- Run the motor at a level speed and load and adjust the AM pot until the ammeter equals the reference ammeter.

Note: The IMX pot sets the current limit circuit's internal reference point. The AM pot sets the output voltage scale. For example: If a motor's rating is 50 amps, the IMX pot calibrates the current limit circuit's internal reference point to 50 amps. The meter has 0 to 2 volt input with 100 amp scale face plate. Next with the motor running under a 50 amp load and using an external ammeter for reference. The AM pot is adjusted until the ammeter reads equal to the reference meter, 50 amps. This sets the scale to 1 volt equals 50 amps. If after the ammeter is calibrated, the IMX pot is changed to 70 amps. This changes the scale to 70 amps equals 1 volt. If the ammeter is not recalibrated, the ammeter will read 50 amps when the armature current is actually 70 amps. The ammeter always must be recalibrated after the IMX pot is adjusted.

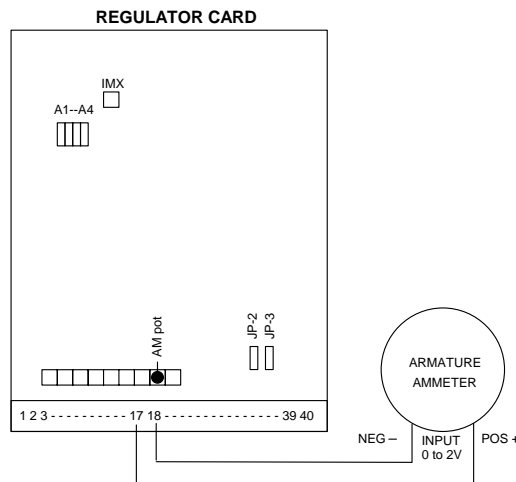

Section 4.15) Field Ammeter Wiring and Calibration

Selecting a meter.

- The ammeter is a voltmeter with a 0 to 2 volt range input (meters are available from ERC).
- The motor's field current rating determines the scale of the meter's face plate.
For example, 0 to 2 volt meter with 10 Amp scale face plate.

Jumper and Potentiometer Settings

Before calibrating the ammeter make all final jumper settings and pot adjustments.

- Make final settings to jumpers F1, F2, F3, F4 and F5
- Set jumper FI - on and FV - off.
- Make final adjustments to potentiometer (pot), IF
- If any of these settings are changed after calibrating the field ammeter, recalibration of the field ammeter is required.

How to calibrate the ammeter.

- An independent ammeter is required as a reference to calibrate the field ammeter.
- The FM pot calibrates the ammeter
- Energize the field and adjust the FM pot until the ammeter equals the reference ammeter.

The IF pot sets the field regulation circuits' internal reference point. The FM pot sets the scale of the field ammeter circuits' output voltage scale. For example: If the motor's field is 6 amps and the meter has a 0 to 2 volt input with a face plate scale of 0 to 10 amps. With the field energized, the FM pot is adjusted until the field ammeter equals the reference ammeter, 6 amps. This sets the output voltage to 1.2 volts at 6 amps. After the field ammeter is calibrated, if the IF pot or F jumpers are changed so that the field is 4 amps. This changes the scale to 4 amps equals 1.2 volts. If the field ammeter is not recalibrated, the ammeter will read 6 amps when the field current is actually 4 amps. The field ammeter always must be recalibrated after the IF pot is adjusted.

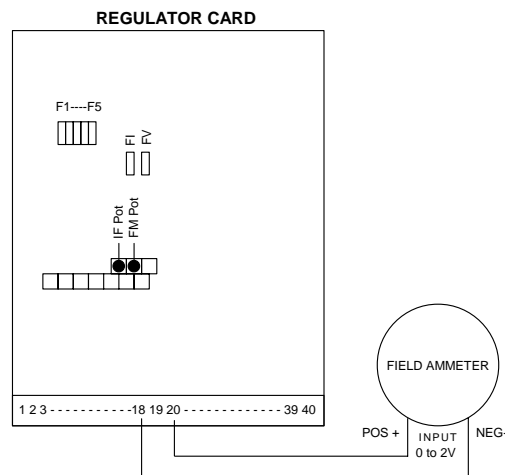

Section 5 Operation and Adjustment

5.1 Check prior to operation

Check all of the following before applying power.

- Check for any loose connections on any of the control circuit terminals, power circuit terminals and fuses.
- Verify all connectors are correctly inserted in the regulator card’s terminals. Carefully inspect for frayed braids of wire. Frayed wires that are and not inserted in the terminal, can cause short circuits or intermittent shorts.
- Use an Ohm meter to check the wiring continuity and the isolation between the wiring and control panel.

5.2 Pre Operation Voltage Checks

Never measure voltage test points when the motor is running.

Item	Measuring Location	Voltage
3 Phase AC Input Power	AC Input Power Buss (L1-L2-L3 or R,S,T)	Within $\pm 10\%$ of Rated Voltage
Field AC Input Power	Terminal Block (L1S, and L2S) (L1F and L2F)	Within $\pm 10\%$ of Rated Voltage
Single Phase Input Power	Terminal Block (L1C and L2C)	110 V _{AC} to 120 V _{AC}
Signal Relay Power	Test Points on Regulator Card (+V to Com)	+19.5 V _{DC} $\pm 1V$
Positive and Negative Power Supplies	Test Points on Regulator Card (+15 to Com) (-15 to Com)	(+15 V _{DC} $\pm 0.5V$) (-15 V _{DC} $\pm 0.5V$)

5.3 Test Run

The primary adjustments have been made at the factory prior to shipping. The jumper settings were covered in section 3 . Fine adjustments should be made in the following sequence prior to full operation.

- Confirm the operation of emergency stop sequence.
- Set the JOG pot to an intermediate position.
- Start the motor using the jog control. If the motor rapidly accelerates past 20% of the motor’s base speed. Stop and check if the tach feedback wires are connected properly and if the tach voltage jumper is correct (see section 3.4). If the motor runs in the wrong direction, for armature feedback check the polarity terminals F1, F2. For tach feedback check the polarity of the tach wires to terminals 1 and 2.
- When the motor operates properly, continue.

5.4 Jog Speed & Acceleration and Deceleration Adjustment

- Start the motor using the jog control.
Note: Jog operates only when the Run not activated.
- Adjust the JOG pot until motor runs at desired speed.
- Jog acceleration and deceleration time are adjusted by the “FT” pot. Clockwise is slower, Counter Clockwise is faster. The scale of the FT pot is with in the range of the setting of the DEC pot.
- Note: Jog’s deceleration time is the same as Emergency Stop’s (E-Stop) deceleration time. The user must decided witch function has priority when setting this adjustment. See section 5.5

5.5 Emergency Stop (E. Stop)

The Statohm IV has two options for emergency stop (i.e. E. STOP).

Option 1) Power Off E. Stop (uncontrolled coast to stop) (default setting). Local regulations may require emergency stop to shut off the drive and let the motor to coast to a stop. When EF jumper is off, the motor will coast to stop and FT relay will switch.

Option 2) Controlled Deceleration E. Stop with power switch off at zero speed. Set the FE jumper on and make connections from terminals 21 to 35 and 23 to 36 (see diagram). The E. Stop deceleration time can be set to equal to or less than the DEC pot deceleration time setting. The “FT” pot adjusts the E Stop deceleration time. Proper adjustment of the OP pot is required for a complete stop (see section 5.6). The OP pot sets the point when the drive switches off.

Emergency Stop mode	Jumper Setting
Power Off Uncontrolled Coast to Stop	EF - Off
Controlled Deceleration Stop with Power Switched Off at Zero Speed	Jumper EF - On and ZD relay terminals are connected 21 to 35 and 23 to 36. See diagram to the right

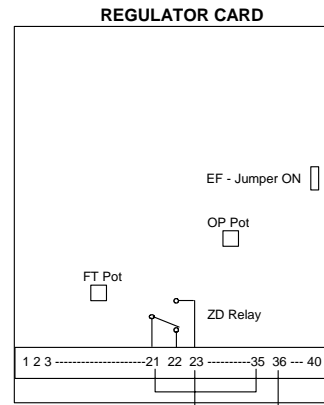

5.6 Zero motor rotation Detection relay and signal light adjustment

The regulator card has a motor rotation detection circuit (i.e. Zero Detection, ZD). The ZD circuit has a SPDT relay on terminals: 21 center pole, 22 normally closed, 23 normally open and a signal light marked ZDL. The switch point of the ZD circuit is set by the OP pot. The switch point adjustable over a range of 0 to 25% of full speed.

- While the motor is stopping adjust the OP pot to the desired switching point. The ZDL signal light will switch on.
- Note: Adjusting the OP pot too low can cause the ZD relay to buzz when the motor is stopped.

5.7 Zero Speed Adjust (12 SCR Regenerative Drives Only)

Regenerative drives that start and stop with a small load, may require special adjustment to make smooth starts, stops and remain stationary when stopped. This problem is common with tach feedback systems. To obtain best results, we recommend using an oscilloscope to view the signal across A+ and A-.

- Turn the acceleration and deceleration pots full clockwise.
- Set the speed reference to zero volts and engage E. Stop and PC. If the motor turns, adjust the ZERO pot until the motor is at a standstill.
- Regenerative drives with tach feedback sometimes exhibit instability is at low speeds and during start and stop. Removing the AP jumper will stabilize the problem by placing a capacitor in parallel with the speed feedback opamp resistor.
- If problems persists, see section: 5.8, Zero Speed Hysteresis Adjustment.

5.8 Zero Speed Hysteresis Adjustment (4 Quadrant, 12 SCR, Regenerative Drives Only)

The regulator card switches the motor from forward to reverse by changing the polarity of the speed amplifier output. The output of the speed amplifier includes ripple from the tach or arm feedback. To minimize the effect of ripple from this feedback. A Hysteresis circuit adjusts the input sensitivity of the to the reverse switch logic. The “HS” pot is usually set on or about 2.5 /10 scale. If the motor is frequently reversed with light load, adjust the “HS” pot clockwise. The Hysteresis circuit is an imprecise adjustment. Set the pot and wait for the drive to stabilize before making another adjustment. Avoid making an excessive number of adjustments.

5.9 Maximum Speed Adjustment for Armature Feedback

See the motor’s data plate to confirm the maximum armature voltage. The drive is preset at the factory for the typical motor. See section 3 for the parameters of your motor and drive. If the drive requires adjustment follow the procedure below.

- When the motor is stopped. Adjust the “CROS” pot full counter clockwise (0/10) and the “MAX” pot to full clockwise (10/10).
- Start the motor, adjust the speed reference to maximum speed and observe the armature voltage. When the motor’s speed has stabilized at maximum speed proceed to the next step.
- Adjust the “CROS” pot to the maximum permissible armature voltage. This calibrates the range of the “MAX” pot. The “MAX” pot will not exceed the setting of the “CROS” pot calibration setting. Another way of describing this is. When the “MAX” pot is full clockwise (10/10). It is equal to the setting of “CROS” pot. If a maximum speed below the maximum permissible armature voltage is required. Adjust the “MAX” pot to required speed.
- Note: If a speed above base speed (above the maximum armature voltage is required). Motor’s with tach generator feedback have the option of field weakening. See Sections: 3.5 Field Regulation and 5.11A Field Weakening Adjustment.

5.9A) Armature Ammeter Wiring and Calibration, See section 4.14

5.10 Maximum Speed Adjustment for DC Tach Generator Feedback

See the motor’s data plate to confirm the maximum armature voltage, base speed and maximum mechanical speed. See the DC tach generator’s data plate to confirm the volts per 1000 RPM. Check the tables below to confirm jumpers are set for DC tach feedback and the correct voltage range for the maximum tach generator voltage. Example: If you have a 50V_{DC}/1000 RPM Tach and your application requires 2,250 RPM. Multiply 2.25 X 50 = 112.5V_{DC}. Select the voltage range of 88V ~ 127V.

Motor Feedback	Jumper Settings
Armature	VF - On SF, TL - Off
DC Tach Generator	SF, TL - On VF - Off

DC Tach Generator Voltage		Jumper Settings
R2 and R5 are 220k ohms (Standard Set Up)	R2 and R5 are zero ohm jumper (Special Set Up)	
41V ~ 60V	27V ~ 41V	S1, S2, S3, S4 - Off
60V ~ 88V	41V ~ 60V	S1 - On S2, S3, S4 - Off
88V ~ 127V	60V ~ 88V	S2 - On S1, S3, S4 - Off
127V ~ 172V	88V ~ 127V	S3 - On S1, S2, S4 - Off
172V ~ 250V	127V ~ 172V	S4 - On S1, S2, S3 - Off

5.10A) Speed Meter Wiring & Calibration, See section 4.13

5.11 Field Amperage Adjustment

Warning, never disconnect the field power while the motor is running. We strongly recommend reading page 41 before continuing. Instructions for connecting the field power and jumper settings are on page 8, section 4.5,.

Temporarily disable field economy by putting on jumper FE. The IF pot adjusts the field amperage within the jumper settings range. We recommend using a ammeter, if one is not available, then calculate the motor's cold field voltage and quickly adjust the field while the field is cold. Important note: Note: the field voltage will not exceed 71% of the input voltage connected to terminals L1F and L2F.

5.11A) Field Weakening Adjustment (DC Tach Feedback Only)

Field weakening offers both constant power and extended speed. Field weakening is only available for motors with tach generator feedback. To enable field weakening, jumpers J7 and J8 must be on. If the field weakening is below half ($\frac{1}{2}$) of full field, put jumper CA on. The field weakening minimum is $\frac{1}{3}$ of full field. The optional 1059A-11 regulator card permits field weakening to about $\frac{1}{4}$ to $\frac{1}{6}$ of full field.

- Adjust the ACC and DEC pots full clockwise (slow).
- Adjust the speed reference to maximum speed and observe the armature and tach generator voltages. When the armature and tach voltages stabilize at maximum, proceed to the next step.
- Adjust the CROS pot to the desired maximum armature voltage.
- Adjust the MAX pot to the desired maximum speed. Warning, do not exceed the motor's maximum speed listed on the motor's data plate. Note: the motor speed will not exceed the DC tach jumper setting, see page 5, section 3.4,.

5.11B) Field Economy

When the motor is not running, full field power is not necessary. Field economy reduces the field power, when the motor is stopped and the PC light has been off approximately six to eight seconds. When the motor is started full field power is automatically reapplied. If you want to disable field economy put the jumper FE on.

5.11C) Field Disable

The field is disabled when the motor has a permanent magnet field or series field and armature. To disable the field loss detection circuit, put the jumper FL on and don't connect power to L1F and L2F. Note: The yellow "F" light will remain on when the field is disabled.

5.11D) Field Ammeter Wiring and Calibration, See section 4.15

5.11E) Field Loss

The 1059A regulator card has field loss protection circuit that shuts off the motor if the field goes below $\frac{1}{6}$ of full field.

5.11F) Field Voltage Regulation

If the application requires field voltage regulation to interface with your equipment. The optional IFC 1084 card is available.

5.12 Armature Voltage and Current Calibration

The CROS pot serves two functions, when field weakening is not used. The CROS pot sets the maximum armature voltage. When you set the armature current jumpers in section 3.2 only the current range was determined. Now you must calibrate the regulator card to the motor’s rated current by adjusting the IMX pot. We strongly recommend the use of an ammeter when making these settings.

- Turn the IMAX pot full counter clockwise. Set the FL and RL pots to 4/10 scale.
- Run the motor at full load. (If running under full load is not possible. See estimating IMX adjustment below.
- When the motor is running with a load adjust the IMX pot to the motor’s rated current.
- All the following percentages are based on the calibrated current set by the IMX pot.
- **Estimating adjusting IMAX** by determining the ratio of the current range. Example: The 42NS4-4 armature jumper is set A-4, the IMX pot will set the current range from a minimum of 38 amps to a maximum of 62 amps. If the motor is rated at 50 amps, (62-38=24 and 38+12=50, half of 24) set the IMX pot at 5/10 (midrange).

5.12B) Current Limit Adjustment The FL (Forward Current Limit) and RL (Reverse Current Limit, 12 SCR, Regenerative drives only) pots are preset at the factory. It is recommended to leave these pots set at the factory settings. If a current limit other than the motor’s rated current is required. See the table below. The scale on the table below is approximate. Fine adjustment should be made with an ammeter.

Potentiometer	100%	150%	200%
FL	4 /10 scale	6 /10 scale	8 /10 scale
RL (12 SCR only)	4 /10 scale	6 /10 scale	8 /10 scale

The above settings are only approximate

5.12C) Forward and Reverse Current Limits (Reverse, 4 Quadrant, 12 SCR, Regenerative Drives Only)

Four pots are used in the adjustment of current limit: IMX, FL, RL and IA.

- The IMX pot sets the motor’s rated current.
- The FL pot sets the forward current limit.
- The RL pot sets the reverse current limit.
- The IA pot sets the one minute timed current overload shut off.

Example: The motor’s rated current is 10 amps. Regenerative drive applications set the forward current limit to the motor’s rating of 10 amps. The reverse current limit is often set higher, in this example 13 amps for extra braking power. Short time periods of over current for regenerative braking should not damage the motor. Make sure the FL and RL pot are set at 100% (see Section 5.9B 4/10 scale). Run the motor in forward with load and adjust the IMX pot to 10 amps. If you want the reverse current limit to be 13 amps for extra braking power. Run the motor in reverse and adjust the RL pot to 13 amps.

If for example you should want the forward current limit to be 6 amps. Run the motor in forward and adjust the FL pot to 6 amps. Now you have a forward current limit of 6 amps and a reverse current limit of 13 amps. Setting the IMX pot to 10 amps calibrates the regulator card’s protection circuits. If the motor should suddenly exceed 25 amps the instantaneous shut off circuit will activate based on 250% of motor’s rating of 10 amps. Not at 32.5 amps (250% of RL) and not 15 amps (250% of FL).

5.12C) One Minute Timed Current Overload Shut Off Adjustment

The overload current can be set up to of current limit for a fixed period of one minute.

- When the power is on and the **motor is not running**. Adjust IA according to table below.

Potentiometer	150% 1 Minute	200% 1 Minute
IA	7/10 scale	9/10 scale

5.12D) Instantaneous Current Overload Shut-Off

When the motor exceeds 250% of it’s rated current (calibrated with the IMX pot). The regulator will instantaneously shut-off the motor. This circuit is not adjustable and cannot be overridden.

5.12E) Armature Ammeter Wiring and Calibration, See section 4.14

5.13 Acceleration & Deceleration Time Adjustment

The jumper settings for accelerate and decelerate time ranges were covered in section 3.6.

- Adjust ACC and DEC pots full clockwise (slowest).
- Start the motor and set the master speed control to desired speed. Adjust the ACC pot slowly counter clockwise until desired acceleration is achieved.

After the motor has reached full desired speed set the master speed control to zero speed. Adjust the DEC pot slowly counter clockwise until desired deceleration is achieved.

5.14 Speed Overshoot and Stability Adjustment

Overshoot and stability are adjusted at the factory but operating conditions at the site may require additional adjustment.

5.14A) Speed Overshoot Adjustment (i.e. Speed Response)

To view the motor's overshoot and stability attach an oscilloscope to test points 10 and com or to the tach feedback wires.

- Adjust the ACC and DEC pots for fast operation (turn the pots counter clockwise).
- Set the JOG pot full clockwise. If jog is not available set the master speed control to 20% of full speed.
- Start the motor while the motor is rapidly accelerating observe the oscilloscope and compare to the drawings in Fig. 5-12.
- Optimum is one overshoot peak as in figure in 5-12 (B). To adjust overshoot use the SR pot.

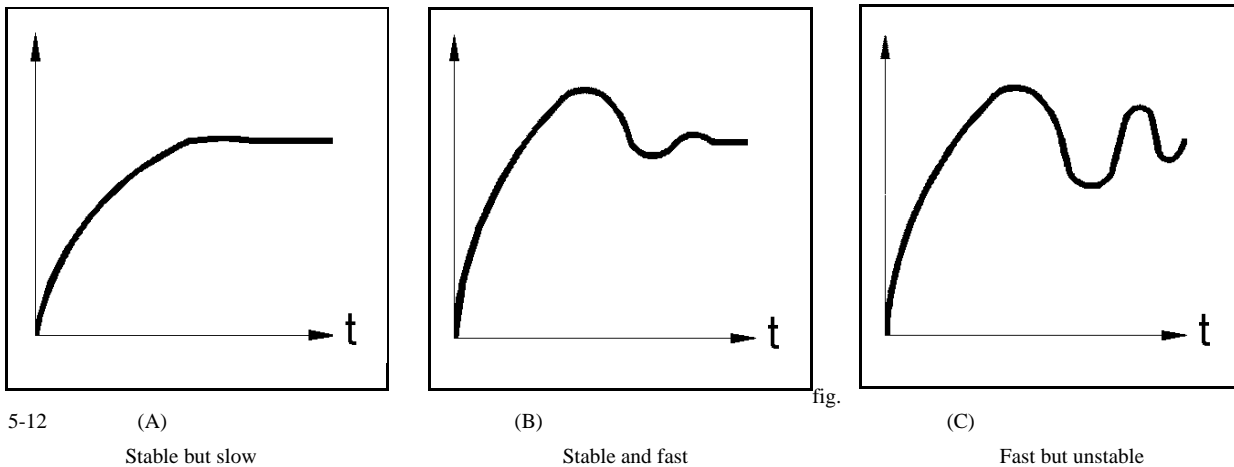

5.14B) Speed Stability Adjustment (i.e. Speed Gain)

- After the SR pot has been adjusted. Return the ACCEL, DECEL and JOG pots to their normal positions.
- Start the motor and observe the oscilloscope. After overshoot has occurred, observe the stability of the motor.
- To adjust stability use the SG pot.

5.15 Speed Feedback Loop Adjustment (i.e. Speed PID)

The ASR feedback loop is adjusted at the factory. If adjustment of the SR and SG pot does not produce satisfactory results. Adjustment of the PI pot may be necessary.

- Record the factory setting of the PI pot ____ /10.
- To increase overshoot adjust the PI pot clockwise.
- To decrease overshoot adjust the PI pot counterclockwise.

5.16 Current Gain Loop Adjustment (i.e. Current PID)

The regulator card has two control loops. The main voltage feedback loop (speed feedback loop) and a secondary minor current feedback loop. The current feedback loop is adjusted by the “IG” pot (i.e. Current Gain). The IG pot is adjusted at the factory but if the current response and stability is poor, adjust the IG pot according to the following instructions.

- Connect a jumper to M3 and M4. Remember to remove jumper afterwards.
- Write down the settings of FL, RL, DEC, ACC and JOG for readjustment after completion of IG adjustment. Adjust FL and RL to 3/10 scale, adjust DEC and ACC to full counter clockwise and adjust JOG to full clockwise. If jog is not available set the master speed control to 20% of full speed.
- Remove all the jumpers from T1, T2, T3, T4 this sets acceleration time to 0.6 seconds.
- Observe the wave form of the armature by connecting an oscilloscope to TP10 and COM. Compare the wave form to figures (a) and (b).
- If the wave form is unstable, make small counter clockwise adjustments to the IG pot.
- If the current response is too slow, make small clockwise adjustments to the IG pot.

Section 5.17) Master Slave Operation

The Statohm IV can be configured for Master Slave operation with or without Master speed gain.

- Terminal 3 is the master speed reference output.
- Terminal 14 is the slave speed reference input.
- Terminal 13 is the commons for both master and slave.

Master Slave with-out Master speed gain

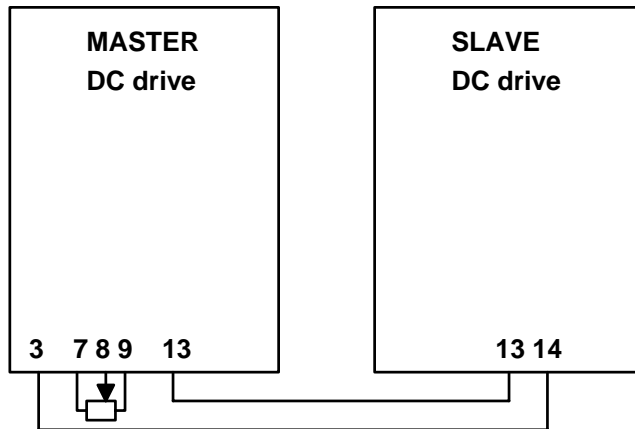

Master Speed Gain permits the speed overshoot, stability to be controlled by the master drive. See sections 5.14 and 5.14B for more details.

- Terminal 10 is the master speed gain output.
- Terminal 6 is the slave speed gain input.

Master Slave with Master speed gain

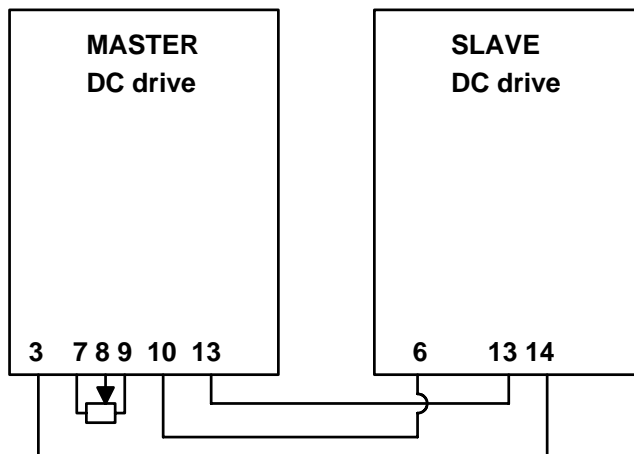

Section 5.18) AC contactor

Not all applications required contactors, below is a elementary diagram of AC contactor circuit.

Elementary Power Connection Diagram with AC Contactor

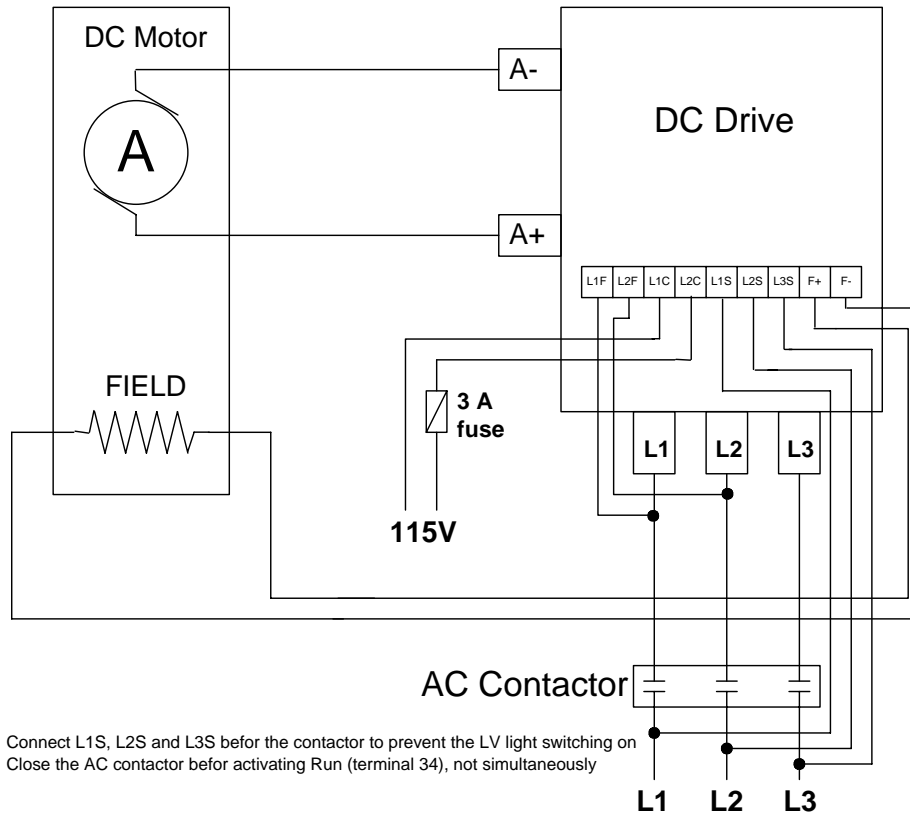

Section 5.19) DC contactor

Warning, don't use a DC contactor with a 12 SCR, 4 quadrant, regenerative drive. DC contactor can be used with a 6 SCR, 2 quadrant drive. A freewheeling rectifier is strongly advised.

Note: Electric Regulator prefers AC contactors, DC contactors can lead to a variety of problems.

Section 6 Trouble Shooting

Trouble shooting may require the following test equipment:

- Digital Multimeter
- DC Ammeter
- Oscilloscope with a isolation transformer and a 10X probe or higher.

When a problem occurs. Write detailed notes of the operating conditions when the problem occurred. Check the Regulator card, if any of the red signal lights are on. Refer to the list below and correct the problem. After the problem has been corrected it may be necessary to press the reset button before operation.

“TG” Tach Generator Loss

Light's when the regulator card is not receiving a signal voltage from the DC tach generator.

“OC” Instantaneous Over Current

When 250% of the motor's rated current is exceeded. The instantaneous over current circuit will shut off the motor.

“OL” One Minute Delay Over Current Shut Off

When 150% of the motor's rated current is exceeded for more than one minute. The time delay over current circuit will shut off the motor.

“FU” Fuse Blown

One or both of the AC input fuses have blown.

“LV” Low input Voltage

The AC input voltage is more than 10% below normal.

“PH” Phase Loss or Phase Sequence Error

Indicates the loss or low voltage of one of the three phases. Also indicates if L1, L2 and L3 are not in correct sequence. See section 4 “Wiring”.

“FL” Field Loss

The field input current is below 13% of normal.

“OH” SCR Over Heat

A thermostat on the SCR heat sink trips at 185°F (85°C) shutting off the motor.

“ES” Emergency Stop

Signals when the emergency stop system is engaged.

6.1 Phase Load Balance

Phase load balance settings are made at the factory. If a phase load balance problem should occur. Check the following two items before adjusting the phase balance.

- Insufficient gain of the ACR amplifier.
- Improper tach generator coupling.

6.1A Observing and Adjusting Phase Load Balance

To observe the phase load balance connect an oscilloscope to test points 10 and com.

- Run the motor at a steady speed and observe the wave form. Adjust the speed and load until a stable wave form is displayed.
- If an unbalanced current wave form is displayed. Adjust pots PH1 to PH6 in the following sequence. PH1, PH6 ... PH2, PH4 ... PH3, PH5
- If improvement is not sufficient adjust the IG pot slightly counter clockwise and repeat adjusting the PH pots.

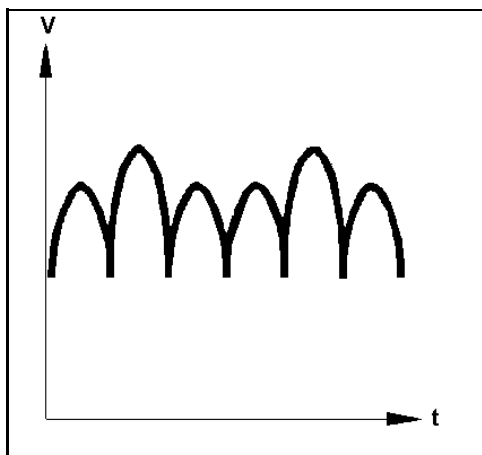

Unbalanced

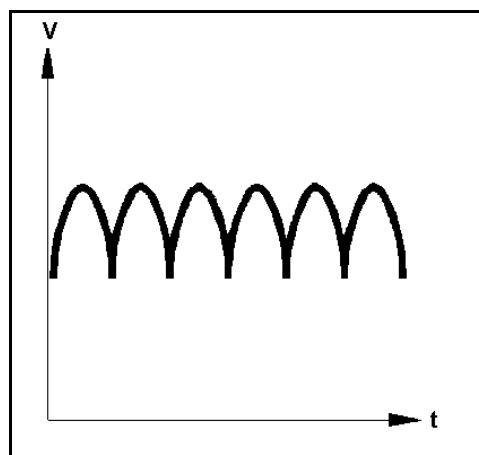

Balanced

Section 6.2 Problem: Motor won't start but none of the red signal lights are on.

Check the following:

- AC input voltage:

- Control circuit relay sequence:

- Jumper JP-10

- Measure the ramp reference signal at test point "4".

Recommendations:

- Check if the unit is receiving power.
Check if the other drive system components are working properly.
- Check if RN1, RN2, JOG and ES relays circuits are wired properly.
When RN1, RN2, JOG and ES relays are open. Check if test point +B is 25V_{DC}
- Jumper JP-10 must be off. The motor will not run when this jumper is on.
- Test point "4" is the acceleration and deceleration ramp signal. When starting the signal should ramp up to 8V or for reverse -8V.

Section 6.3 Problem: Motor Runaway

Check the following:

- TG Jumper

- Tach Generator circuit.

- Tach feedback: Check voltage of test point "1". The normal voltage range is -0.02 to -8.5 V_{DC}

- Armature feedback: Check voltage of test point "2". The normal voltage range is +0.02 to +8.5 V_{DC}

- Armature feedback: Check the armature voltage plug connected to the bottom left corner of the synchronization card.

- Measure the field current.

- Phase to the field is not correct.

- The motor's field is not correctly connected.

- Check jumper settings and continuity.

Recommendations:

- The TG jumper must be on for both Armature and Tachometer feedback. TG - On
- Check if the tach generator circuit wiring is faulty.
Check if the polarity is correct.
See section 4.11 DC Tach Generator
- If no voltage is present at test point "1" Check wire connections. If wire connections are good. The regulator card may need to be replaced.
- If no voltage is present at test point "2" Check wire connections. If wire connections are good. The regulator card may need to be replaced.
- If this plug is not connected or reversed the motor will run away. The correct sequence is red wire right (H) and white wire left (N). See bottom of page 39 for details.
- If field current is insufficient. Check if jumpers F1-F5 are set right and the continuity is good. See section: 3.1 Field Current and 3.5 Field Regulation.
- Line L1 and L2 must be connected respectively to L1F and L2F. If these connections are not correct, the field voltage will be too low, causing the motor to run fast.
- See section 6.12B on page 32.
- Check if SF, TG, TL and S1-S4 are set right and the continuity is good. See section: 3.1 Motor Feedback

Section 6.4 Problem: Fuses blow immediately after start and the “OC” signal lights.

Check the following:

Recommendations:

- | | |
|--|--|
| <ul style="list-style-type: none">• The DC armature circuit is shorted.• The load on the motor is stalled.• SCR failure (i.e. thyristor)• Improper setting of current limit or current protection circuits.• Measure voltages of test points “1” - “6”.• Measure the resistance between CT1R & CT1W and CT2R & CT2W on the SYNC card.• Rapid change of load or motor flash-over.• Check for the presence of a surge during the operation of the external contactor or relays. | <ul style="list-style-type: none">Check the DC power circuit.Check the load on the machine.Disconnect L1, L2, L3 and A+, A- and measure the resistance between them. The typical resistance between them should be about 100kΩ. If the resistance is low the SCR modules may need to be replaced. Contact the factory for assistance.Check if jumpers A1-A4 are set right and the continuity is good. See sections: <u>3.2 Armature Current</u> and <u>5.12 Armature Current Calibration</u>If voltage is present when the motor is stopped the regulator card may need to be replaced.The normal resistance is only a few ohms or less.Check the machine load and motor commutator.If a surge is present. Connect a noise suppresser to the external contactor and relays. |
|--|--|

Section 6.5 Problem: Unstable Speed

Check the following:

- Measure test points “+” and “-” to “com”.
- Measure the voltage of test point “4”
- Unstable field voltage.
- Improper installation of the tach generator.
- Armature feedback only:
- Improper adjustment of “SR” or “SG”.
- Excessive field weakening.
- Current Limit
- Thyristor (SCR) has failed

Recommendations:

- The normal voltages are +15V_{DC} and -15V_{DC} respectively. If they are not nominal the SYNC card may need to be replaced.
- If there is any variation. Check the speed pot wiring.
- If the regulator is set for field weakening with armature feedback the speed will be unstable. Set the regulator card for constant field.
See section: 3.3 Motor Feedback
- Check the tach’s mounting, coupling and wiring. Check for noise pick up on the tach’s wiring.
- Check for instability of power supply input voltage. If present correct the problem.
- See sections: 5.14, 5.14A and 5.14B
- Field weakening applications. The field should not go below 1/3 to 1/6 of normal full field.
Example: Full field is 300V_{DC} . Field weakening to 100V_{DC} or less will cause unstable motor speed. A special regulator card PN 1059A-11 is required.
- The drive is repeatedly reaching current limit (bouncing agianst current limit).
- A thyristor has failed and must be replaced.

Section 6.6 Problem: Motor will not go to full speed.

Check the following:

- Insufficient voltage.
- Insufficient current.
- Measure voltage of test point “4”
- Measure 3 phase input voltage.
- Improper calibration of speed meter
- Excessive field current.
- Load is greater than motor’s rating.

Recommendations:

- Readjust the “MAX” pot. (Do not exceed motor’s rating)
- Refer to section 3.1 Armature Current
(Do not exceed motor’s rating)
- Normal is about 8 volts.
- Should be within $\pm 10\%$
- Check the speed with another calibrated meter for comparison.
- Check with calibrated ammeter and compare with motor’s ratings.

Section 6.7 Problem: Excessive overshoot and undershoot.

Check the following:

- The acceleration or deceleration is too short despite the load’s large inertia.
- Excessive overshoot, undershoot and unstable level speed.

Recommendations:

- Adjust “ACC” or “DEC” pots.
See Section 5.13 Acceleration and Deceleration Adjustment
- Improper adjustment of the speed regulation loop.
Adjust “SR”, “SG” and “PI” pots. See section 5.14, 5.14A, 5.14B and 5.15

Section 6.8 Problem: Overload fault “OL” signal light.

Check the following:

- Overload of motor.
- Check field current.
- Improper setting of “IA” pot.

Recommendations:

- The “OL” signal light may turn on if an intermittent load exceeds the square root mean value of 100%.
Check the intermittent load of the motor.
- Low field current reduces the power of the motor.
- See section 5.12C

Section 6.9 Problem: The ES, OH, VL signal lights are on and can not be reset.

Check the following:

Plug CN1 on the Regulator card and SYNC card maybe loose.

Check voltage from terminal board positions 35 & 38 to +B. The voltage should be $25V_{DC} = \pm 3V_{DC}$

Recommendations:

Check CN1 is plugged on properly.

If $25V_{DC}$ is not present the $115V_{AC}$ transformer may be damaged, check the transformer. If the transformer output voltages are good. The SYNC card should be replaced.

Section 6.10 Problem: Signal lights R and PC are on, the F, AP, ZD flash and the relays buzz.

Check the following:

Check the armature connections.

Recommendations:

The armature circuit is bad or open. Trouble shoot and correct the problem.

Section 6.11 Problem: Field loss is detected

Check the following:

Check the motor's name plates' field specifications. Measure the field current and voltage to determine if they are comply with the specifications.

Note: Remember to disable field economy when making field measurements.

Recommendations:

If the field current is too low and the voltage corresponds to the field resistance. The F jumper is set too low.

If the field current and voltage are correct. The F jumper could be set too high.

Explanation: The field has a current regulation circuit, but the field voltage will not exceed $70\% \pm 5\%$ of the AC input voltage connected to terminals L1F and L2F. The current is limited to the voltage available.

First example: The 42NS1-4 is connected to a motor with a 1 amp field and the F jumper is set for 7.1 amps (F1). The voltage will go up to maximum available and the current will be 1 amp. The field loss circuit will detect the current is too low.

Second example: The 42NS1-4 is connected to a motor with a 1 amp field and the F jumper is set for 1.4 amps (F4). When the motor has rapid load increase, the field will drop momentarily and trigger the field loss detection circuit. The best setting for a motor with 1 amp field would be 0.6 ~1.2 amps (F5).

If the field current is too low and the voltage is too high for the field's specified resistance. The field possibly has bad connections or is beginning to fail.

Section 6.12A) Problem: The armature current is too high at low speed and small load.

Check the following:

Read the field specifications on the motor's name plate. Then measure the field current and voltage to determine if they comply with the specifications. Note: Remember to disable field economy when measuring the field. Field economy is disabled by placing the FE jumper on.

Recommendations:

One of two problems are possible:

1) If the field input power is incorrectly connected. The field power will be too low. The motor will draw too much current during start and run too fast if the load is not too large. Common mistakes are L3 is connected to L1F or L2F or the single phase 110V ~ 120V is connected to L1F or L2F. The correct connections are shown below.

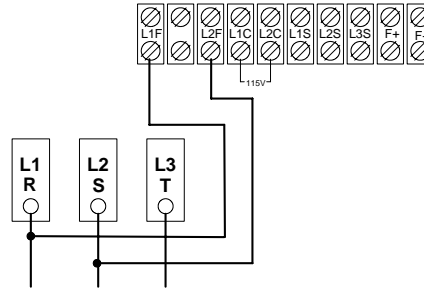

2) The field isolation is deteriorating and beginning to fail. The current is jumping from one winding to the next. The is field controlled by an current regulation circuit. The current is held at normal but not making enough ampere turns. This results in the field being too weak, replace the motor.

Section 6.12B) Problem: During acceleration or heavy load the field is too low.

Check the following:

Check the motor terminal box for leads S1 and S2. Some motors have leads S1 and S2, some motors don't. If S1 and S2 are present and not connected. See the diagram to the right for how to connect them. The letter "S" stands for Stabilizing field. If the motor doesn't have S1 and S2, then the stabilizing field is connected internally.

Diagram

Elementary Motor Connection Diagram

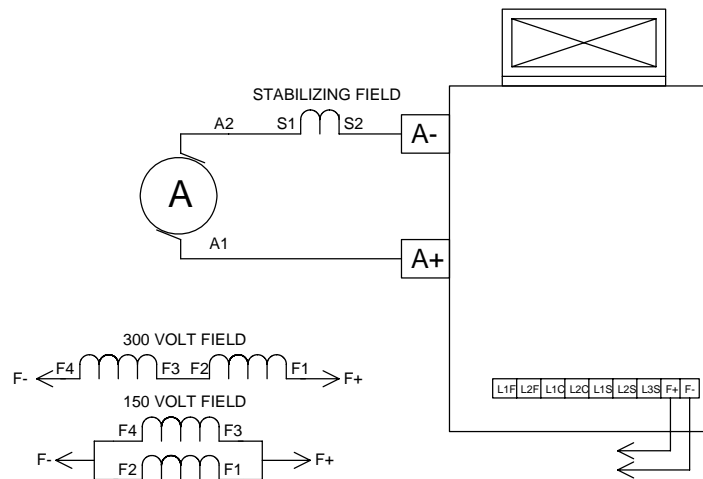

Section 6.13 Problem: The PH light is on

Check the following:

Several problems are possible.

1) Lines L1, L2 and L3 should be connected respectively to terminals L1S, L2S and L3S.

Also check the plugs on the synchronization card. L1S goes to R4 (red wire) L2S goes to S4 (white wire) L3S goes to T4 (blue wire). See diagram to the left.

2) Possibly transformer TR1, TR2 or TR3 has failed. Disconnect leads to terminals L1S, L2S and L3S and measure the resistance between these terminals. The normal resistance should be $1k\Omega, \pm 10\%$. Also visually inspect the legs on the transformers for breakage.

3) When the motor is running if the PH light switches on. The phase load may not be balanced. The most common reason for this problem is unequal phase voltage. This occurs when the voltage of one phase is 25% below the others. This problem is often caused by loose power connections.

4) When the motor is running if the PH light switches on. The SCR thyristors may not be phase correctly. See sections 6.1 and 6.1A.

Diagram

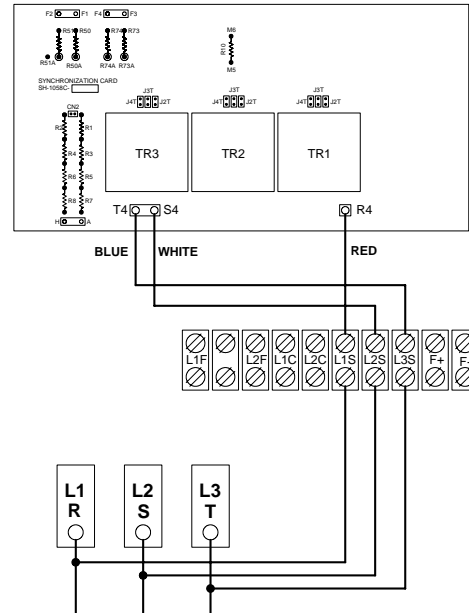

Section 6.14) The “F” light is dimly lite but field loss is not detected

Check the following:

An error was made connecting power to the field. Line 3 (L3) is connected to either L1F or L2F. The correct connections are shown in the diagram to the right.

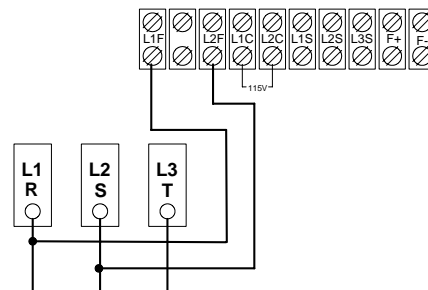

Section 6.15 Regulator Card Connections

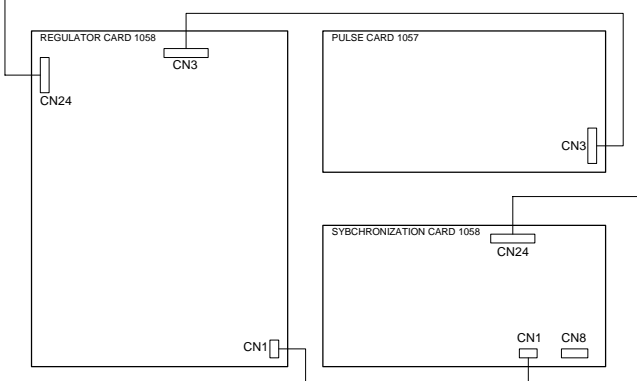
Warning !	Diagram
<p>Incorrect connections will irreparably damage the regulator card, synchronization card and pulse card. Carefully refer to the diagram to ensure correct connections.</p>	

Section 6.16 Utility Company Transfer Switch Problems (PH light disable)

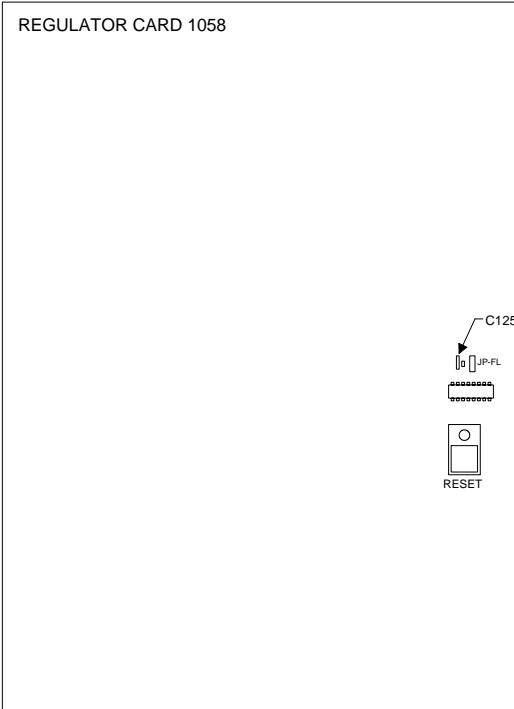
Warning !	Diagram
<p>Disabling the PH light will not resolve incorrect input power connections! Disabling the PH light and running the drive with improper phasing will eventually damage the motor and the drive.</p> <p>If the drive runs normally for hours or days then suddenly displays PH light fault and resetting clears the PH light. Then the drive runs normally until the same time the next day, or until the same day and time each week. This problem is typically the result of the utility company transfer switch in areas with old utility systems. As a last resort, disabling the PH light circuit can be done.</p> <p>Bypass capacitor C125 by laying it on its left side and solder a wire across it's leads.</p>	

Blank Page

ELECTRIC REGULATOR

CARLSBAD, CA. USA

Tel (760) 438-7873

Fax(760) 438-0437

Information@electricregulator.com

"S" Model Ratings

Model Number	Max Amps	230VAC Max HP	480VAC Max HP	575VAC Max HP
S1	31	7	14	17
S2	70	15	30	37
S3	110	25	50	62
S4	180	45	90	110

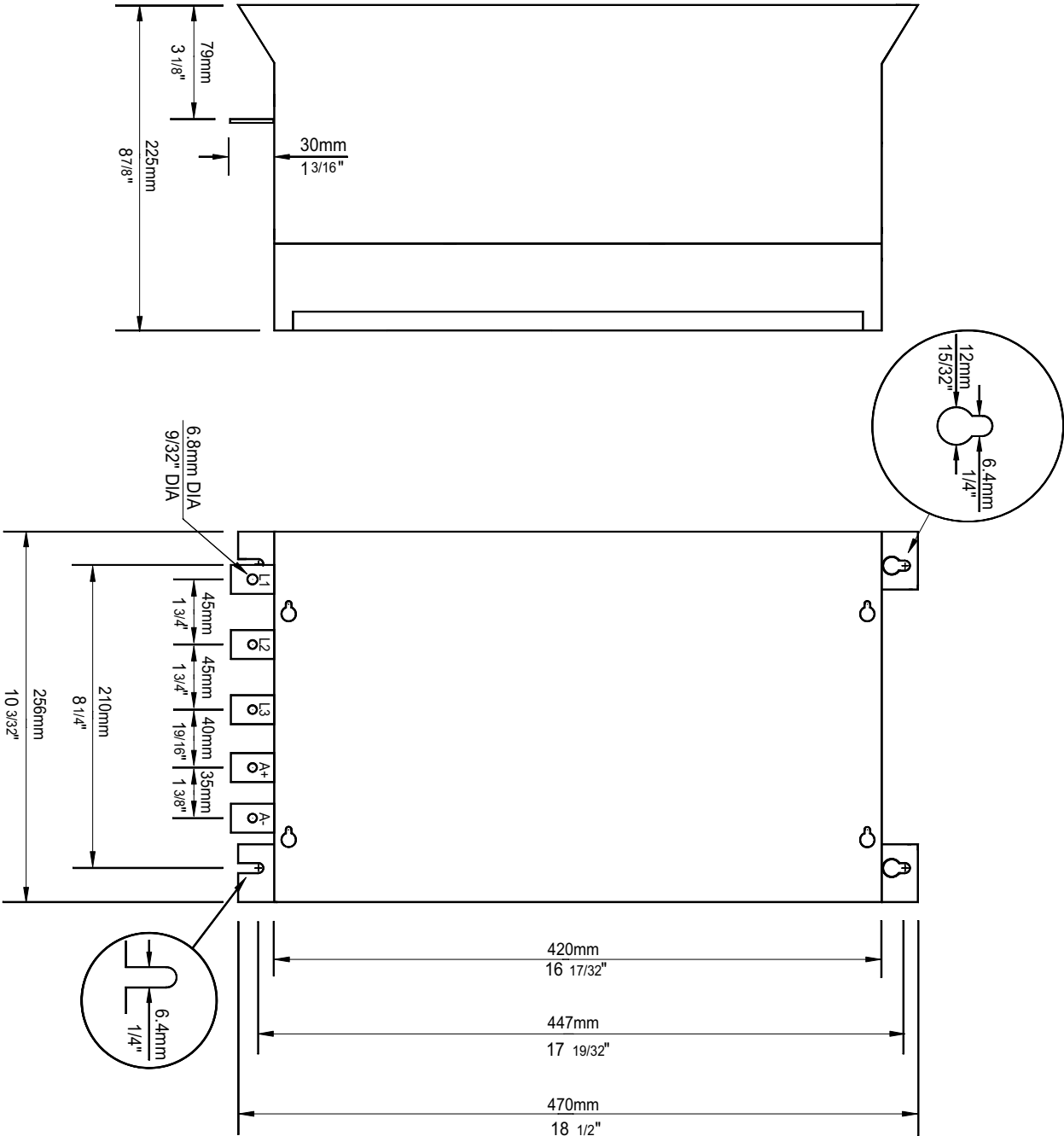

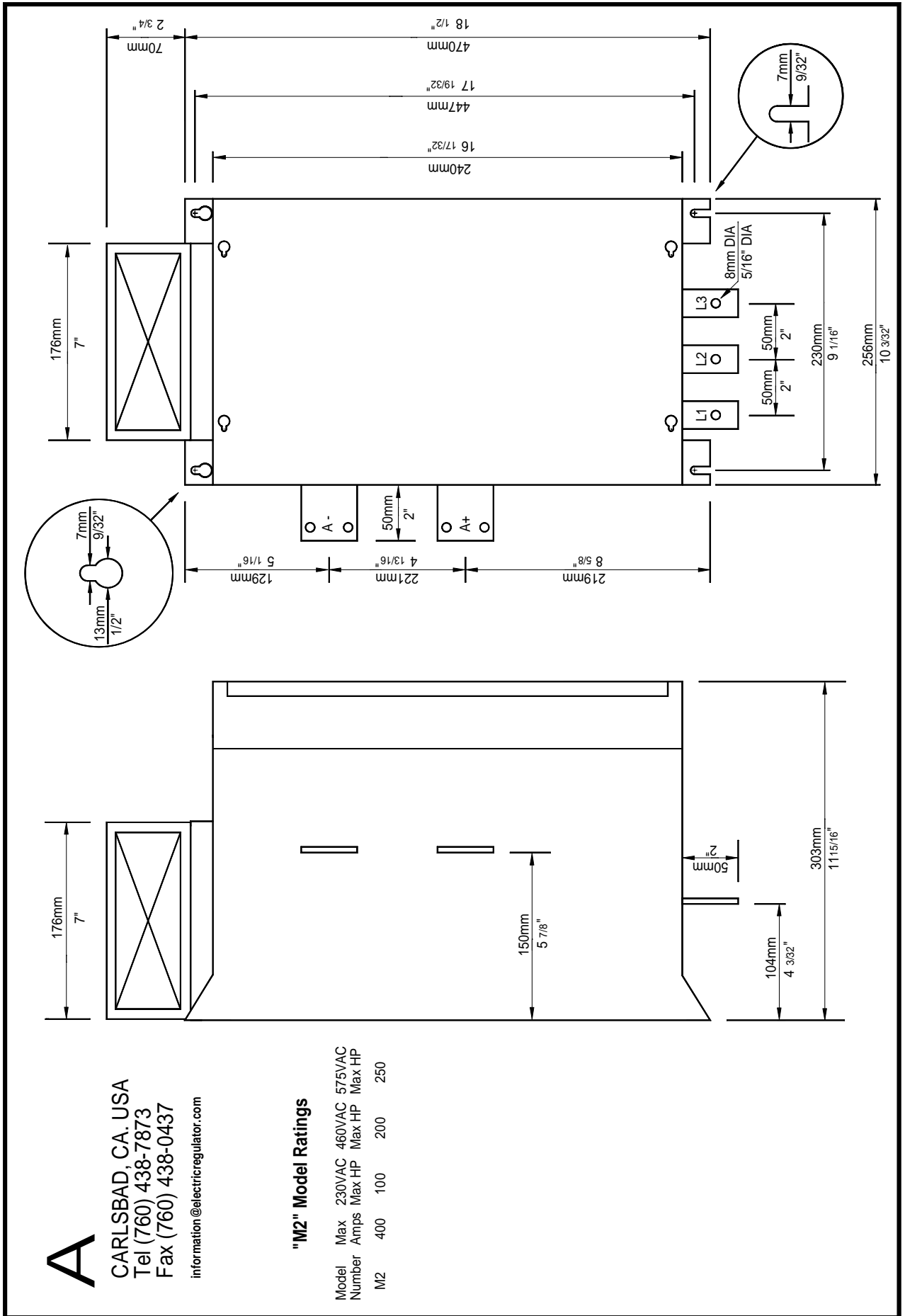

A
 CARLSBAD, CA. USA
 Tel (760) 438-7873
 Fax (760) 438-0437
 information@electricregulator.com

"M2" Model Ratings

Model Number	Max Amps	230VAC Max HP	460VAC Max HP	575VAC Max HP
M2	400	100	200	250

A

Carlsbad, CA. 92009 USA
 Tel (760) 438-7873
 Fax(760) 438-0437
 information@electricregulator.com

"M3" Model Ratings

Model Number	Max Amps	230VAC Max HP	460VAC Max HP	575VAC Max HP
M3	550	125	250	312

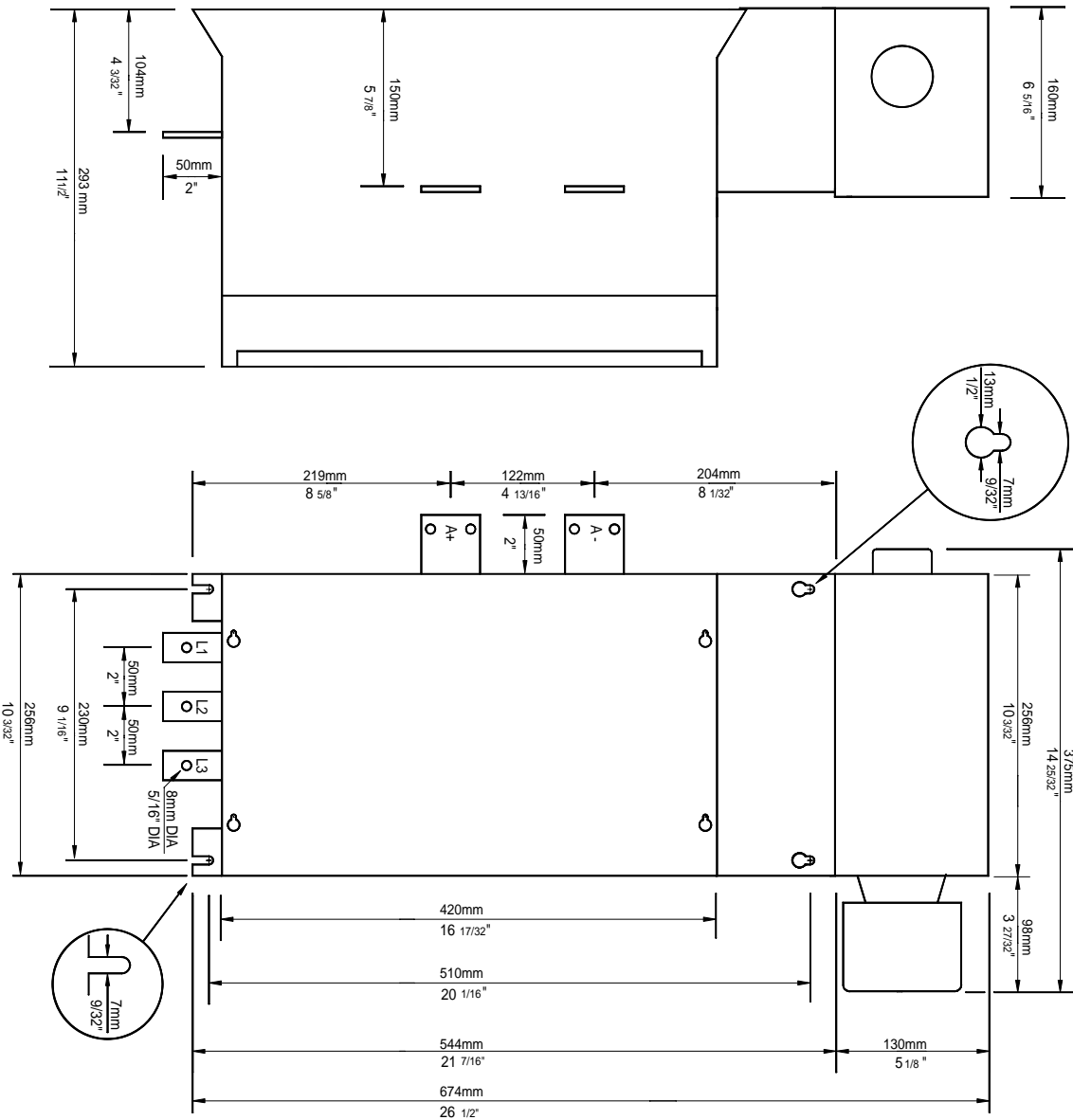

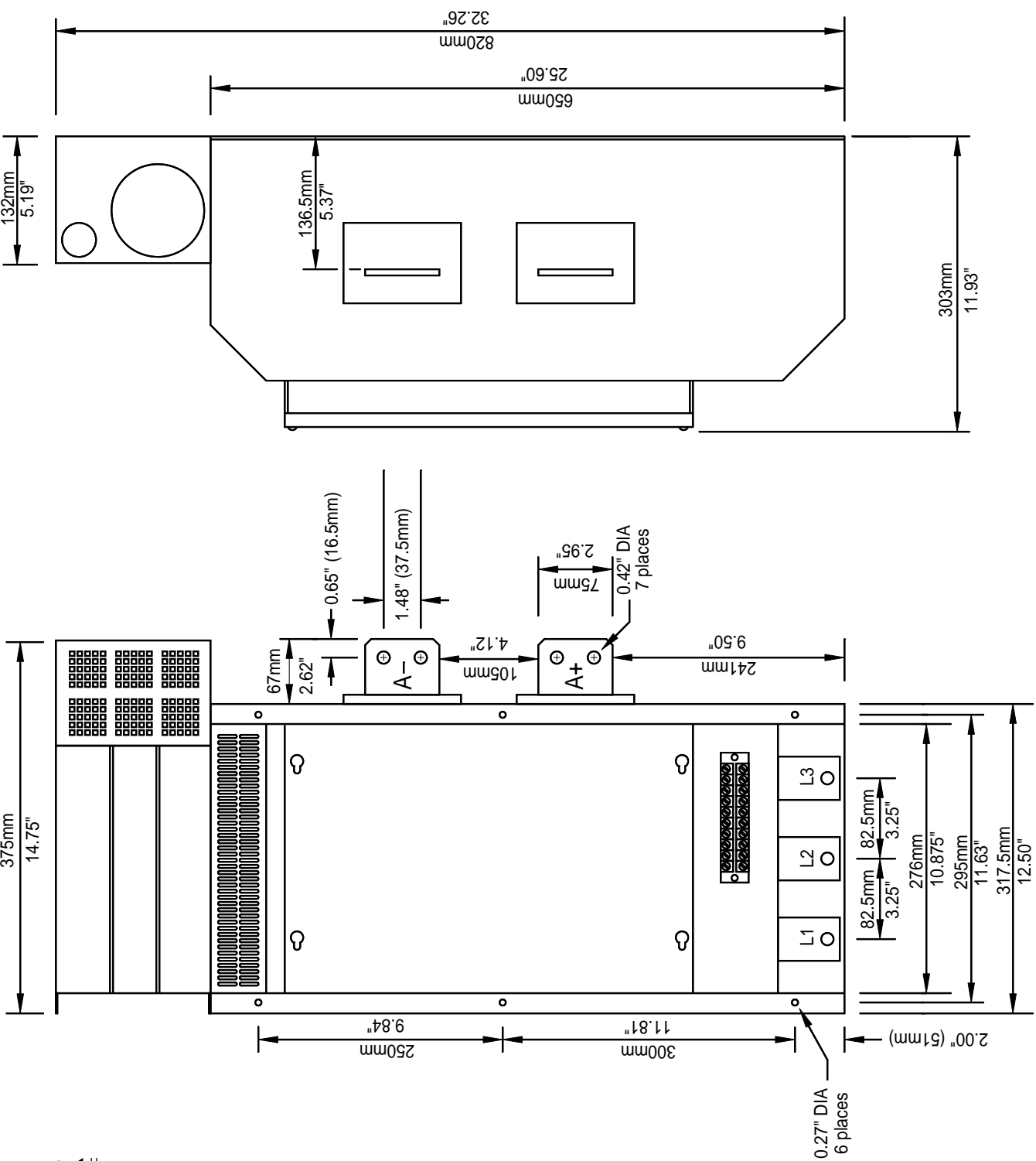

**ELECTRIC
REGULATOR**
 Carlsbad, CA 92009 USA
 Tel. (760) 438-7873
 Fax (760) 438-0437
 Tech@ElectricRegulator.com

Model: L-1
 Amps: 720
 230VAC: 200HP
 480VAC: 400HP
 575VAC: 500HP

ELECTRIC REGULATOR

Carlsbad, CA. 92009 USA
 Tel (760) 438-7873
 Fax (760) 438-0437
 tech@electricregulator.com

Model: L-2
 Amps: 910
 240VAC: 250HP
 480VAC: 500HP
 575VAC: 625HP

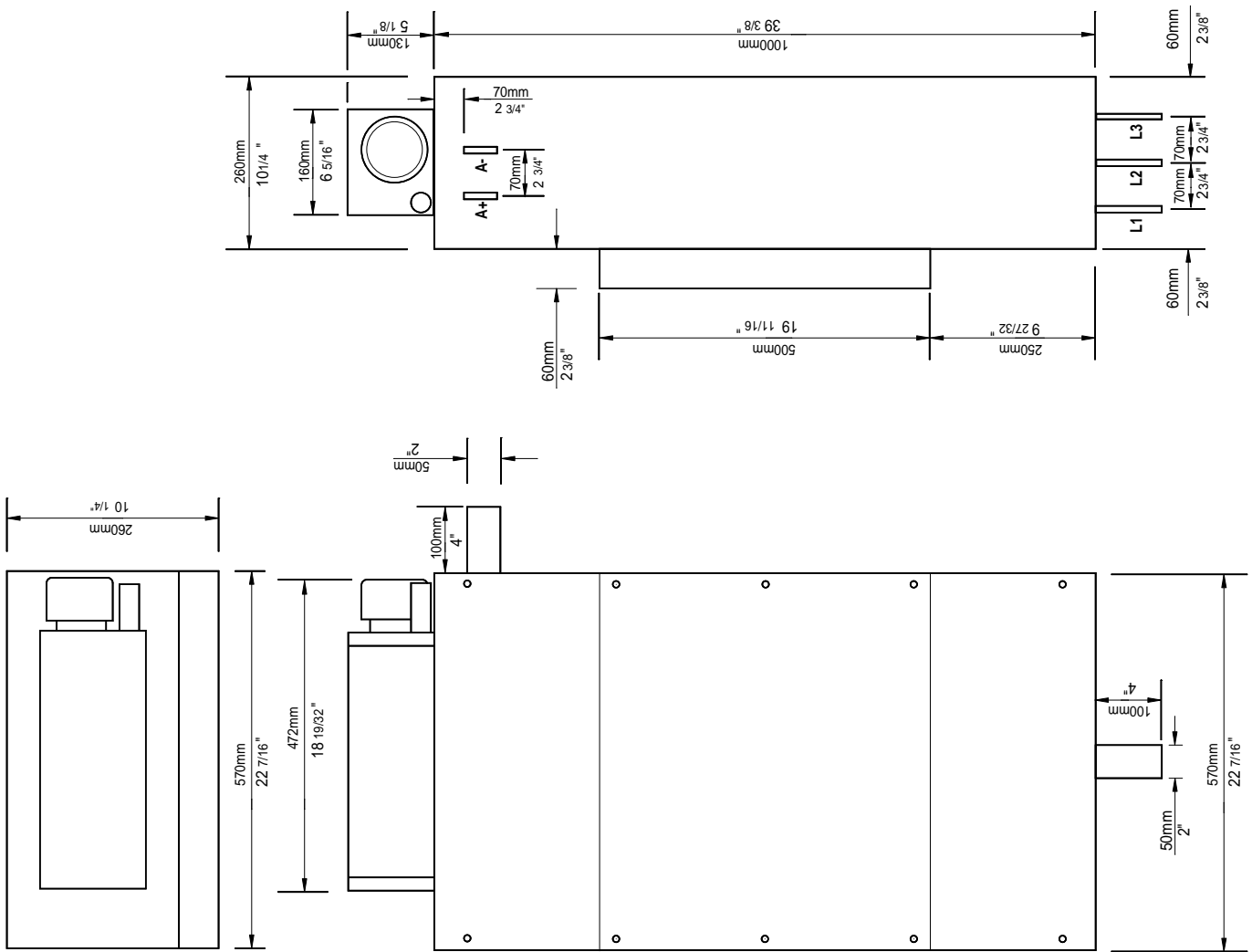

IFC 1084 card connections

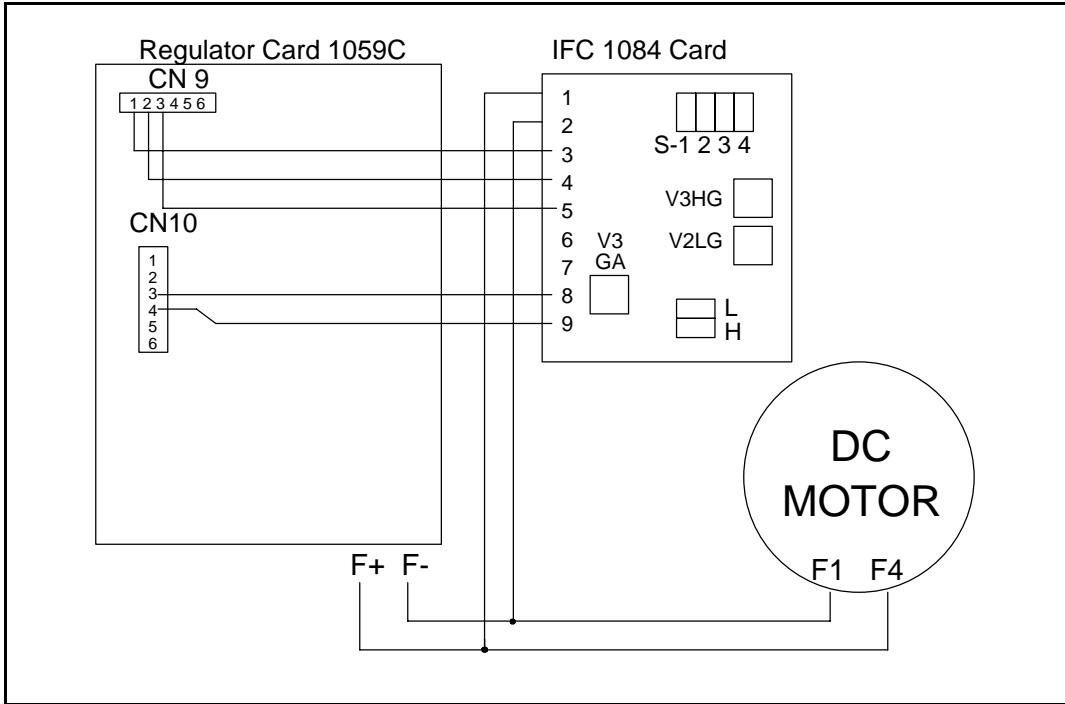

41FS Auxiliary Field Supply for High Current Fields

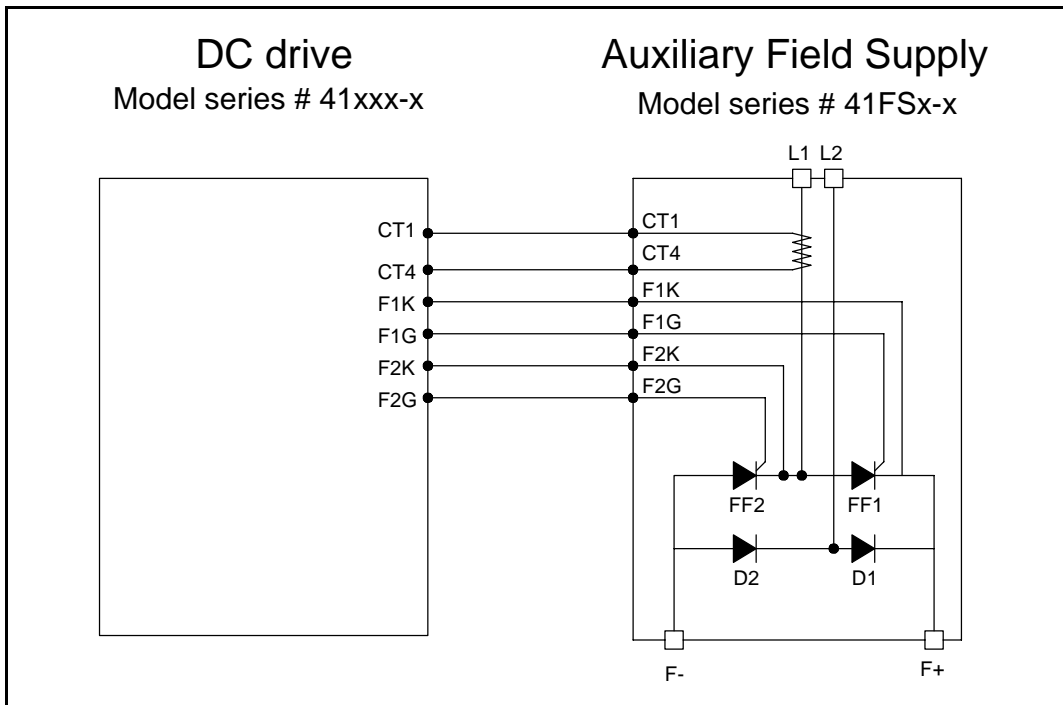

The Synchronization Card 1058C (i.e. SYNC CARD 1059C) can be modified to work with different model drives and input voltages by changing resistor values and jumpers.

Part Number	Input Voltage	Armature Voltage
1058C-01	200V ~ 240V	240V
1058C-02	380V ~ 480V	500V

Input Voltage 200V ~ 240V, 3 ϕ , Armature 240V

Model Number	Resistor R10	Resistors R1, R2, R3, R4, R5, R6, R7, R8	Resistors R50, R51, R73, R74	Transformers TR1, TR2, TR3 Jumpers	Regulator Card Field Jumper	Field Amps
42NS1-2 42RS1-2	66.5 Ω ½ Watt tol +/- 2%	each 237k Ω ¼ Watt tol +/- 1%	each 47.5k Ω ½ Watt tol +/- 5%	J2T, J2S, J2R-ON J3T, J3S, J3R-OFF J4T, J4S, J4R-OFF	F1	4.3 ~ 7.1
					F2	2.1 ~ 4.3
					F3	1.4 ~ 2.1
					F4	0.7 ~ 1.4
					F5	0.6 ~ 1.7
					No Jumper	0.3 ~ 0.6
42NS2-2 42NS3-2 42NS4-2 42RS2-2 42RS3-2 42RS4-2	47.5 Ω ½ Watt tol +/- 2%	each 237k Ω ¼ Watt tol +/- 1%	each 47.5k Ω ½ Watt tol +/- 5%	J2T, J2S, J2R-ON J3T, J3S, J3R-OFF J4T, J4S, J4R-OFF	F1	6 ~ 10
					F2	3 ~ 6
					F3	2 ~ 3
					F4	1 ~ 2
					F5	0.8 ~ 1.0
					No Jumper	0.5 ~ 0.8
42NM2-2 42RM2-2	28 Ω ½ Watt tol +/- 2%	each 237k Ω ¼ Watt tol +/- 1%	each 47.5k Ω ½ Watt tol +/- 5%	J2T, J2S, J2R-ON J3T, J3S, J3R-OFF J4T, J4S, J4R-OFF	F1	10 ~ 17
					F2	5 ~ 10
					F3	3.3 ~ 5
					F4	1.7 ~ 3.3
					F5	1.3 ~ 1.7
					No Jumper	0.8 ~ 1.3

Input Voltage 440V ~ 480V, 3 ϕ , Armature 500V

Model Number	Resistor R10	Resistors R1, R2, R3, R4, R5, R6, R7, R8	Resistors R50, R51, R73, R74	Transformers TR1, TR2, TR3 Jumpers	Regulator Card Field Jumper	Field Amps
42NS1-4 42RS1-4	66.5 Ω ½ Watt tol +/- 2%	each 475k Ω ¼ Watt tol +/- 1%	each 95k Ω ½ Watt tol +/- 5%	J2T, J2S, J2R-OFF J3T, J3S, J3R-OFF J4T, J4S, J4R-ON	F1	4.3 ~ 7.1
					F2	2.1 ~ 4.3
					F3	1.4 ~ 2.1
					F4	0.7 ~ 1.4
					F5	0.6 ~ 1.7
					No Jumper	0.3 ~ 0.6
42NS2-4 42NS3-4 42NS4-4 42RS2-4 42RS3-4 42RS4-4	47.5 Ω ½ Watt tol +/- 2%	each 475k Ω ¼ Watt tol +/- 1%	each 95k Ω ½ Watt tol +/- 5%	J2T, J2S, J2R-OFF J3T, J3S, J3R-OFF J4T, J4S, J4R-ON	F1	6 ~ 10
					F2	3 ~ 6
					F3	2 ~ 3
					F4	1 ~ 2
					F5	0.8 ~ 1.0
					No Jumper	0.5 ~ 0.8
42NM2-4 42RM2-4	28 Ω ½ Watt tol +/- 2%	each 475k Ω ¼ Watt tol +/- 1%	each 95k Ω ½ Watt tol +/- 5%	J2T, J2S, J2R-OFF J3T, J3S, J3R-OFF J4T, J4S, J4R-ON	F1	10 ~ 17
					F2	5 ~ 10
					F3	3.3 ~ 5
					F4	1.7 ~ 3.3
					F5	1.3 ~ 1.7
					No Jumper	0.8 ~ 1.3
42NM3-4 42NL1-4 42NL2-4 42RM3-4 42RL1-4 42RL2-4	19 Ω 1 Watt tol +/- 2%	each 475k Ω ¼ Watt tol +/- 1%	No Resistor Open Circuit	J2T, J2S, J2R-OFF J3T, J3S, J3R-OFF J4T, J4S, J4R-ON	F1	15 ~ 25
					F2	7.5 ~ 15
					F3	5 ~ 7.5
					F4	2.5 ~ 5
					F5	2 ~ 2.5
					No Jumper	1.3 ~ 2

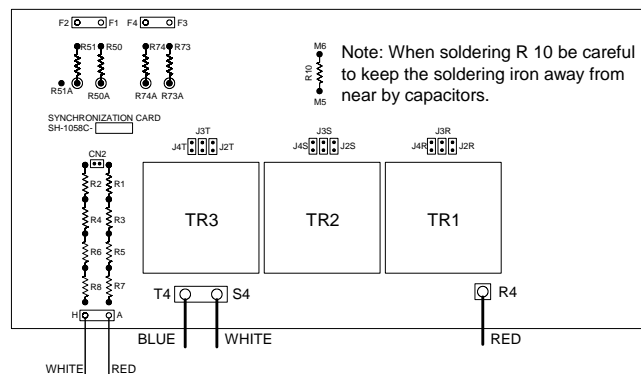

Oscilloscopes

Viewing the armature voltage with an oscilloscope requires special care. The oscilloscope can not be grounded. The oscilloscope's power can not be grounded or connected to the neutral. The oscilloscope and step down transformer can not rest on a grounded surface, such as the floor or metal electrical enclosure. Resting the oscilloscope and transformer on a sheet of plywood or thick card board often provides sufficient isolation from ground. An expensive oscilloscope is not required, an inexpensive oscilloscope is recommended.

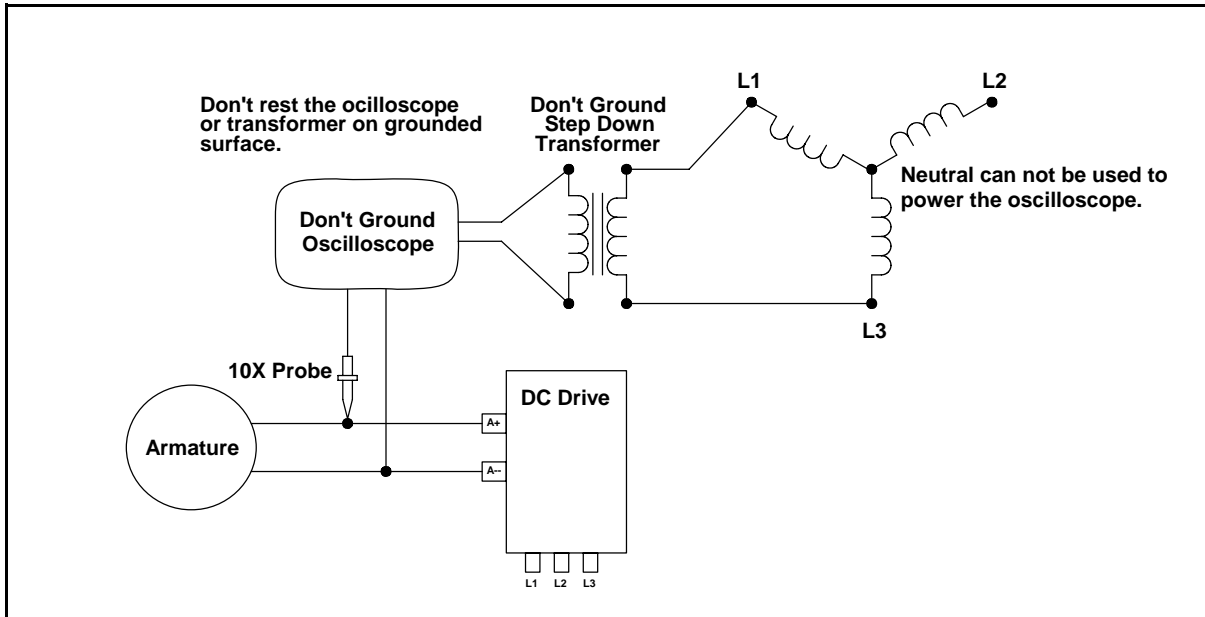

Viewing the field voltage with an oscilloscope also requires the same special care plus additional precautions. Before starting the motor, first view the field voltage to ensure the oscilloscope is set up correctly. Take extra precautions so that the field can not be accidentally grounded while the motor is running. If the field were accidentally grounded while the motor is running will result in catastrophic damage to the motor and the drive, that would require replacement of the drive and rewinding the motor.

Supplemental Field Information

Field Power

The field power is vital to DC motors. **Never disconnect the field power when the motor is running.** Also if the field does not have power, don't apply power to the armature.

Why is the field vital? The field induces resistance in the armature, without the field the armature has virtually no resistance.

Example: A 100 HP DC motor is running at full load; the armature is 500 volts, 150 amps. The armature has an effective resistance of 3.333 ohms. If the field power is disconnected the armature resistance will drop to about 0.08 ohms (virtually zero) and the armature current will immediately go up to 6,250 amps. Within mille seconds both the motor and drive will incurred serious damage that is often irreparable.

Field Voltage

The field is a ampere circuit, the field voltage will vary with temperature.

Example: The 3212AT frame, 100 HP, DC motor field current is specified to be 3.5 amps. When the motor is cold, 20°C (68°F) the field resistance is 66.8 ohms, the voltage would be 234 volts. When the motor warms up to 40°C (104°F) the field resistance will increase to 85.7 ohms and the field voltage would be 300 volts.

Stabilizing field winding

Modern DC motors have the stabilizing field connected internally. Older DC motors sometimes have the field stabilizing terminals, giving the user a choice. Below is a diagram of how to connect the stabilizing field winding.

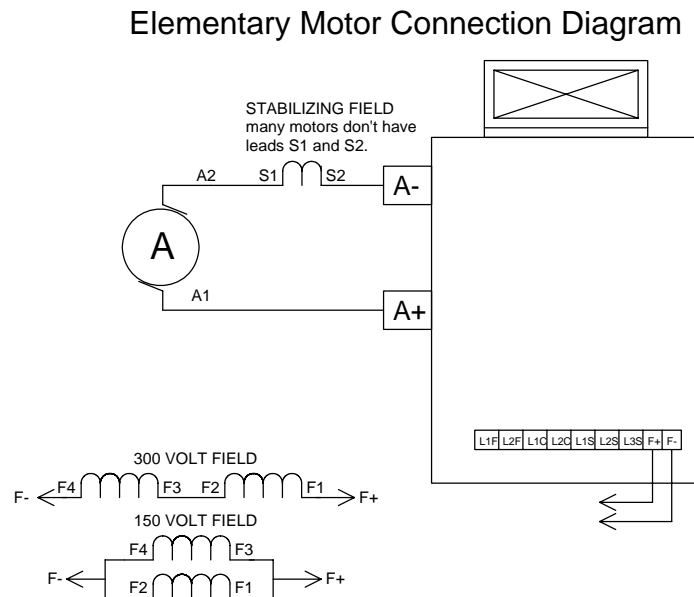

A

Carlsbad, CA. 92009 USA

DC42 REGULATOR CONTROL BLOCK DIAGRAM

DWG 9044

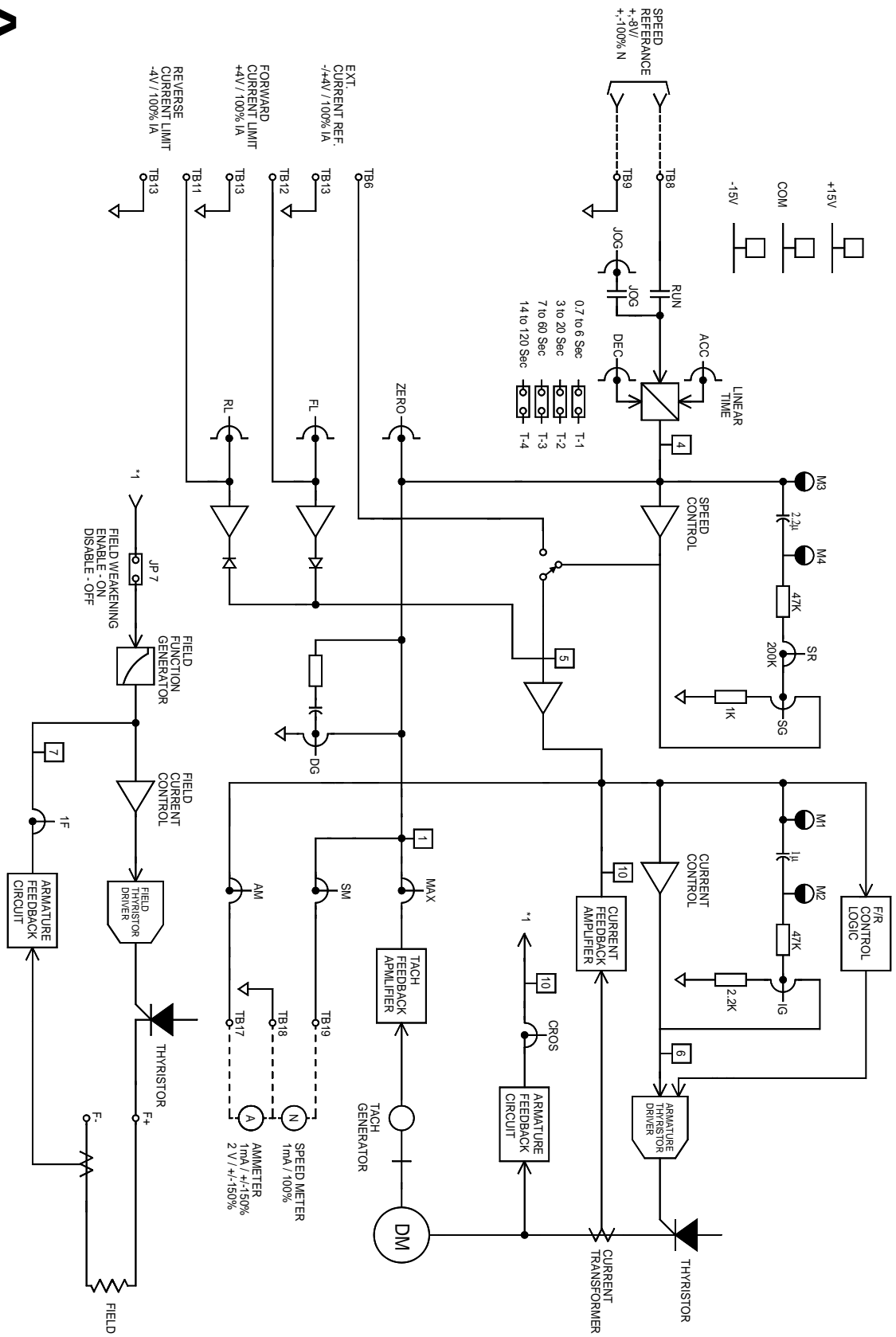

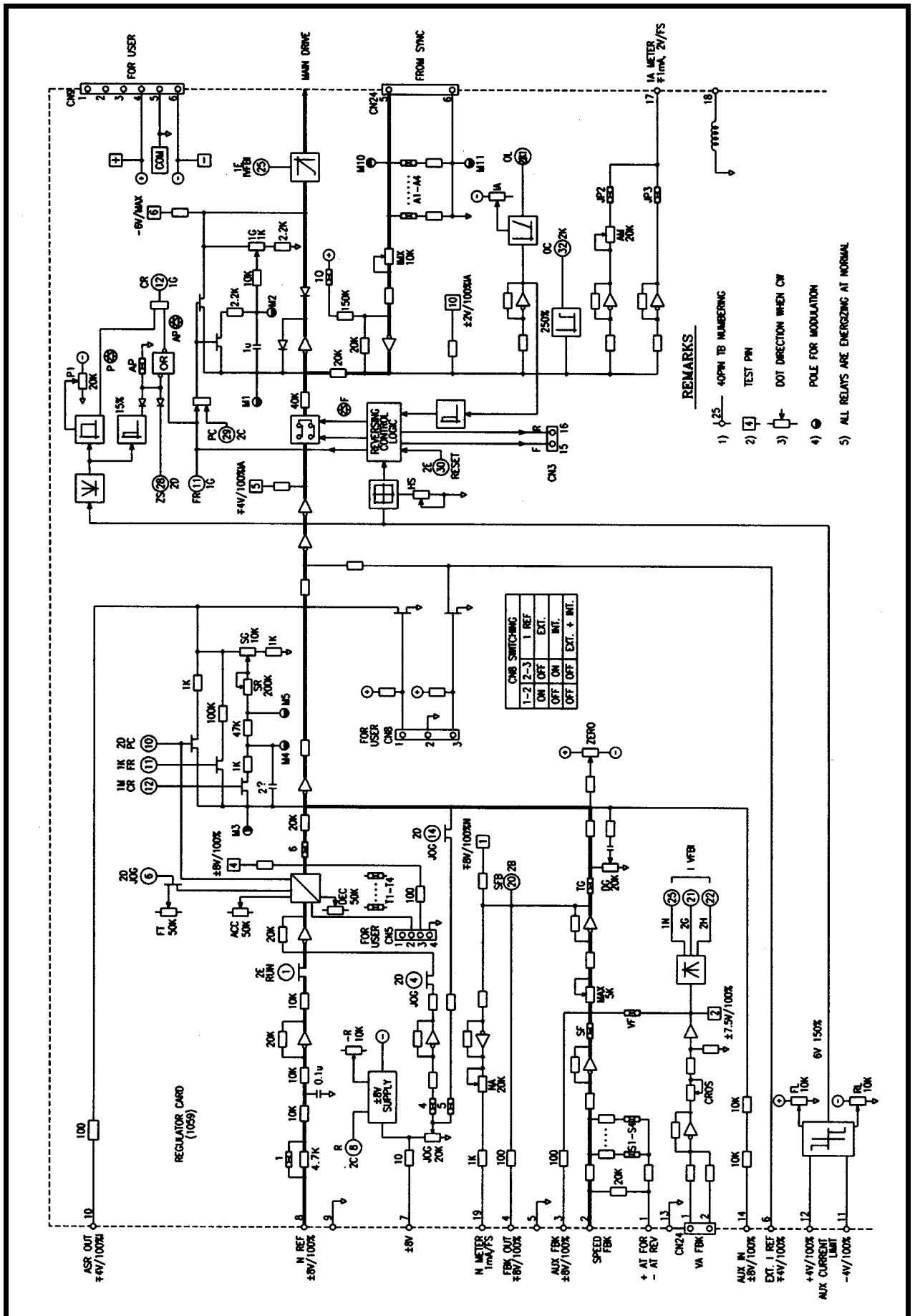

Regulator Block Diagram (DWG 9042-1)

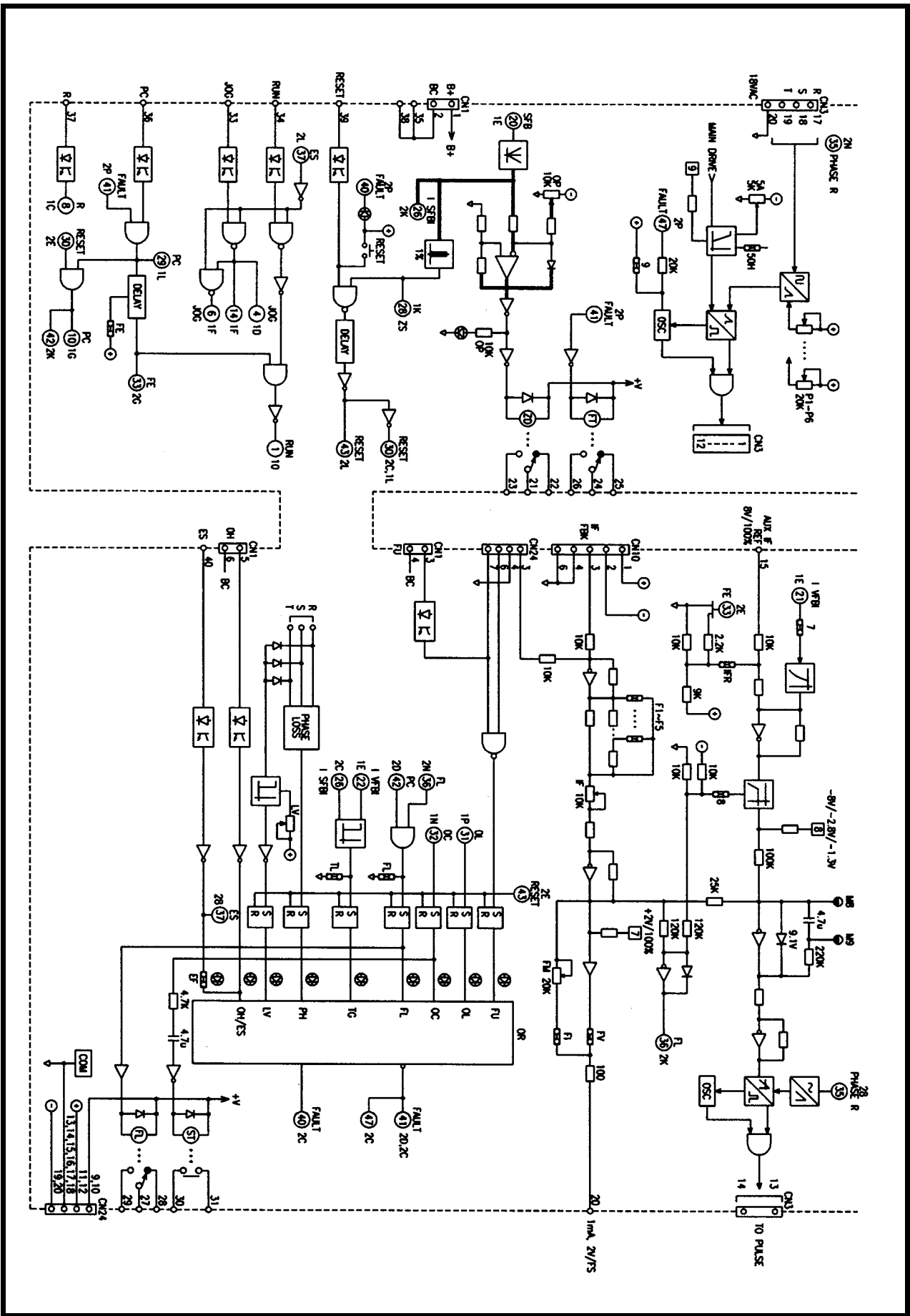

Regulator Block Diagram (DWG 9042-2)

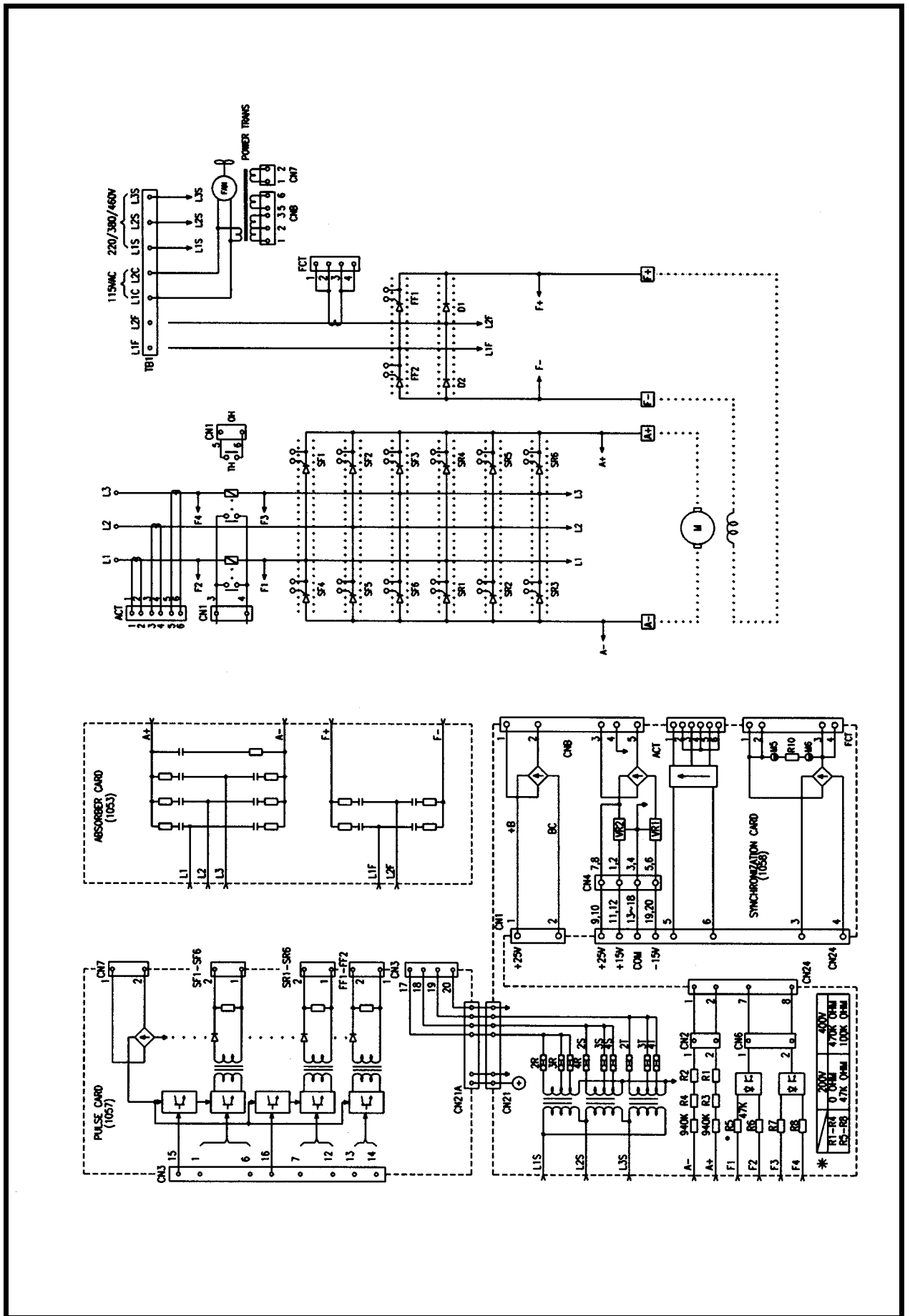

2 QUADRANT, 6 SCR

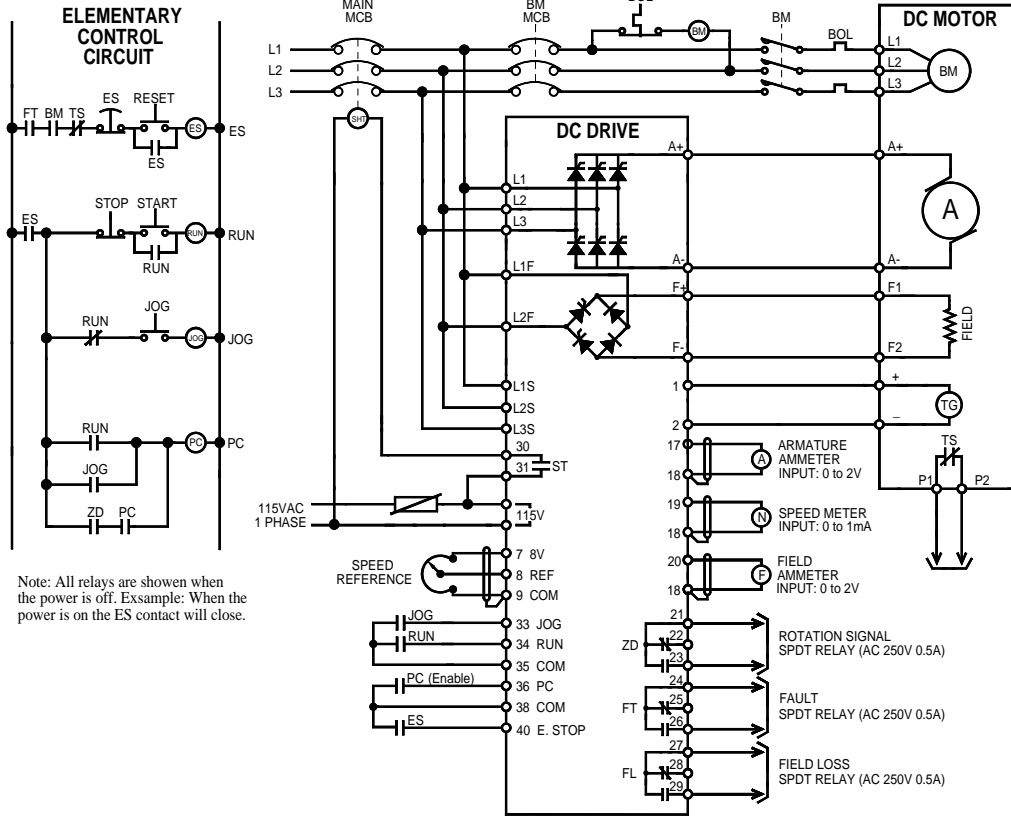

4 QUADRANT, 12 SCR, REVERSING & REGENERATIVE BRAKING

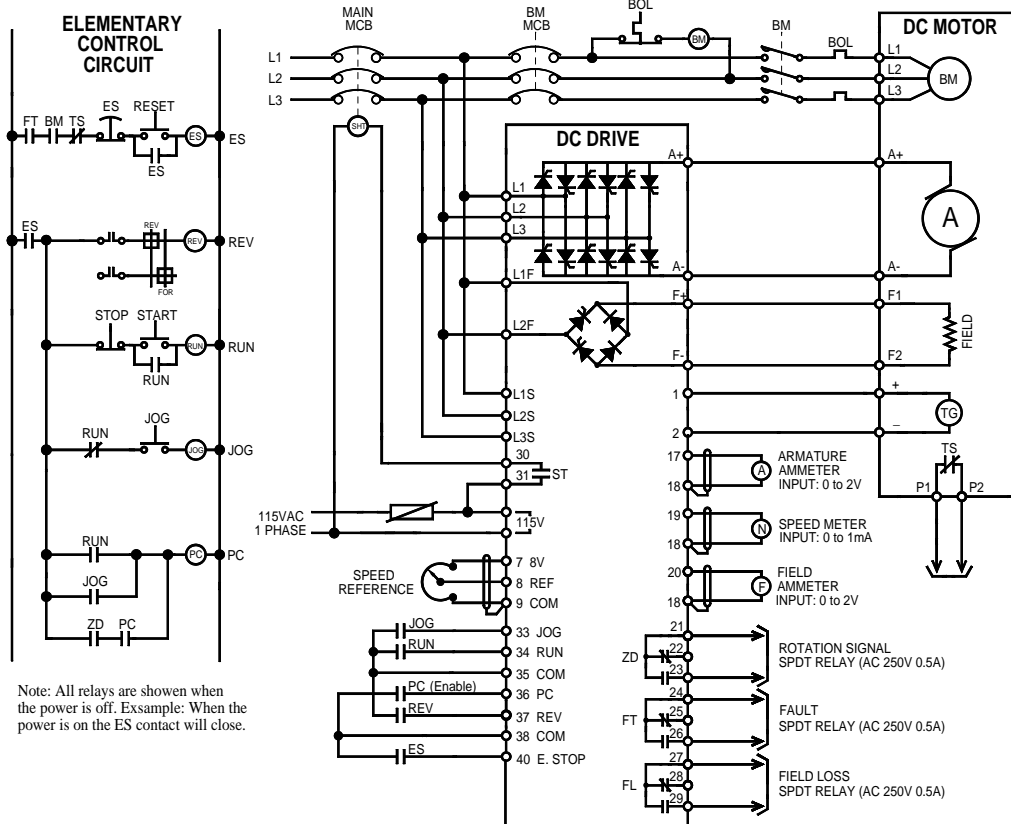

Regulator Terminal Table

TERMINAL	DESCRIPTION
1	(+) Input: DC Tach Generator Feedback
2	(-) Input: DC Tach Generator Feedback
3	Master Speed Reference output (± 8 Volts / 100% N)
4	Auxiliary Speed Feedback input (± 8 Volts / 100% N)
5	Common for 4
6	Slave Speed Gain input ($\pm 4V$ / 100% IA)
7	+8V Speed Reference Power Supply
8	Speed Reference Input
9	Common for Speed Reference Power Supply
10	Master Speed Gain Output ($\pm 4V$ / 100% IA)
11	Auxiliary Reverse Current Limit Reference Input ($-4V$ / 100% IA) (12 SCR Only)
12	Auxiliary Forward Current Limit Reference Input ($+4V$ / 100% IA)
13	Master, Slave and Auxiliary Common for Terminals 3, 6, 11, 12, 14 and 15.
14	Slave Speed Reference Input (± 8 Volts / 100% N)
15	Auxiliary Field Current Reference Input (± 8 Volts / 100% N).
16	Not Used
17	Armature Ammeter Output (0~2V / 100% IA)
18	Common for Terminals 17, 19 and 20.
19	Speed Meter Output (0~1mA / 100% N)
20	Field Ammeter Output (0~2V / 100% IF)
21	ZD SPDT Relay: Tc / Center Pole (Rating: 250V _{AC} , 0.5 A)
22	ZD SPDT Relay: Tb / Normally Closed (Motor Rotation opens it)
23	ZD SPDT Relay: Ta / Normally Open (Motor Rotation closes it)
24	FT SPDT Relay: Tc / Center Pole (Rating: 250V _{AC} , 0.5 A)
25	FT SPDT Relay: Tb / Normally Open when 115V power is on.
26	FT SPDT Relay: Ta / Normally Closed when 115V power is on.
27	FL SPDT Relay: Tc / Center Pole (Rating: 250V _{AC} , 0.5 A)
28	FL SPDT Relay: Tb / Normally Closed when 115V power is on.
29	FL SPDT Relay: Ta / Normally Open when 115V power is on.
30	ST SPST Relay: Normally Open (Input Circuit Breaker Shunt Trip)
31	ST SPST Relay: Normally Open (Rating: 250V _{AC} , 0.5 A)
32	Not Used
33	Jog Input
34	Run (i.e. Start) Input
35	Common for 33, 34 and 37
36	PC (Enable) Input
37	Reverse Input (Regenerative Only)
38	Common for 36, 39 and 40
39	Auxiliary Reset Input
40	Emergence Stop Input

REGULATOR CARD 1059D and earlier depicted
 REGULATOR CARD 1059F eliminated jumpers 2, 3, 6, FV, FI and added jumpers 11 and 12

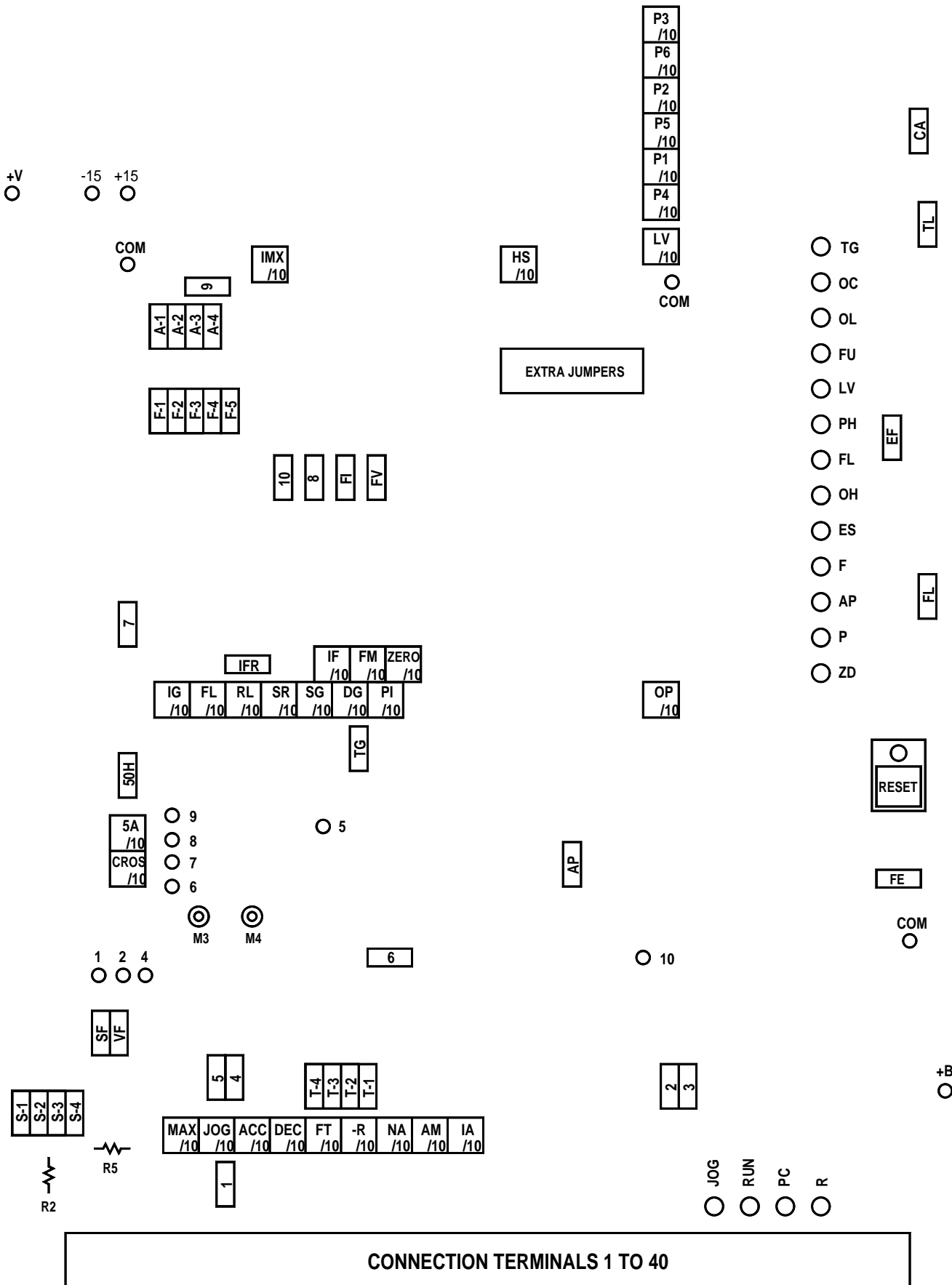

POTENTIOMETER TABLE

POT.	DESCRIPTION
5A*	Factory Reserve, Do not adjust.
ACC	Acceleration Time Adjustment (See Section 3.6)
AM	Armature Ammeter Calibration (See Section 4.14)
CROS	Field weakening Crossover Point (See Section 5.9)
DEC	Deceleration Time Adjustment (See Section 3.6)
DG*	PID Lead Compensation (i.e. ASR Lead Comp)
FL*	Forward Current Limit (See Section 5.12)
FT	Jog and E. Stop Accel & Decel (See Sections 5.4 & 5.5)
FM	Field Ammeter Calibration (See Section 4.15)
HS	Zero Speed Hysteresis (See Section 5.8)
IA*	Instantaneous Over Current Trip (See Sections 5.12A & 5.12B)
IF	Field Economy (See Section 5.11A)
IG*	Current Gain (See Section 5.16)
IMX	Armature Current Reference Point (See Section 5.12)
JOG	Jog Speed (See Section 5.4)
LV*	Low Input Voltage Shut Off Level (set at factory)
MAX	Max. Speed (i.e. Max. Armature Voltage) (See Section 5.9)
NA	Speed Meter Calibration (See Section 4.13)
OP	ZD Relay Latch Point (See Section 5.6)
PI*	PID (See Section 5.15)
-R	For/Rev Speed Balancing (See Section 5.12)
RL	Reverse Current Limit (Regenerative Drives Only)
SG	Speed Gain (i.e. Speed Stability) (See Section 5.14B)
SR	Speed Response (i.e. Speed Overshoot) (See Section 5.14A)
P1*	1F/1R SCR Phasing Balancing (See Section 6.1A)
P2*	2F/2R SCR Phasing Balancing (See Section 6.1A)
P3*	3F/3R SCR Phasing Balancing (See Section 6.1A)
P4*	4F/4R SCR Phasing Balancing (See Section 6.1A)
P5*	5F/5R SCR Phasing Balancing (See Section 6.1A)
P6*	6F/6R SCR Phasing Balancing (See Section 6.1A)
ZERO	Zero Speed Adjustment

Note: * We strongly suggest the user not change the factory setting.

RED SIGNAL LIGHT TABLE

Light	Description
ES	Emergency Stop
FL	Field Loss (Lights when current is 13% or less)
FU	Fuse Blown
LVL	Low Voltage Level (Lights when voltage is 70% or less)
OC	Instantaneous Over Current Shut Off (see IA pot)
OL	60 Sec Current Overload
PH	Phase Loss & Phase Sequence Error
TGL	Tach Generator Signal Loss

YELLOW SIGNAL LIGHT TABLE

Light	Description
AP	Auto Precondition
F	Forward
JOG	Jog in Operation
P	PI Gain (for special applications only)
PC	Pre-Condition (i.e. Enable System before start)
R	Reverse (12 SCR, Regenerative Only)
RUN	Run (i.e. Start)
ZD	Zero Detect (Detects Motor Rotation)

JUMPER TABLE

Jumper	Function
50H	50 Hz Power-ON / 60 Hz Power-OFF
A1~A4	Armature Current Range Settings (See section 3-3)
AP	PC Terminal: Disable-ON / Enable - OFF
CA	Field Weakening Ratio: Below 1/2 -ON / Above 1/2 -OFF
EF	E. Stop: Controlled Decel: Enable-ON / Disable-OFF
F1~F5	Field Current Range (See section 3.5)
FE	Field Economy: Enable-OFF/ Disable-ON
FI	Field Ammeter: Enable-ON / Disable -OFF
FL	Field Loss Signal: Enable-OFF / Disable -ON
FV	Aux. Field Voltmeter: Enable-ON / Disable -OFF
IFR	Internal Field Regulator: ON / External Field Regulator -OFF
JP-1	Speed Reference Scale: 8V- ON / 10V- OFF
JP-2	Armature Ammeter: Enable -ON / Disable -OFF
JP-3	IA internal reference: Enable - OFF / Disable - ON
JP-4	Jog Signal: Enable -ON / Disable -OFF
JP-5	Jog PID: Enable-ON / Disable -OFF
JP-6*	PID: Enable-ON / Disable -OFF (i.e. ASR, Speed Gain)
JP-7	Field Weakening: Enable-ON / Disable -OFF
JP-8	Field Current Limit: Enable-ON / Disable -OFF
JP-9	Driver Test: Enable-ON / Disable -OFF
JP-10*	Calibrate AM pot to zero: Enable-ON / Disable -OFF
JP-11*	1059F card only, Manufacturer test equipment use only
JP-12*	1059F card only, Manufacturer test equipment use only
S1~S4	DC Tach Generator Voltage (See section 3.2 and 4.11)
SF	Tach Feedback: Enable-ON / Disable -OFF (i.e. Speed Feedback)
T1~T4	Accel and Decel Time Range (See Section 3.6)
TG	Tach Feedback ASR: Enable-ON / Disable -OFF
TL	Tach Loss: Enable-ON / Disable -OFF
VF	Armature Feedback: Enable-ON / Disable -OFF

Note: * We strongly suggest the user not change the factory setting.

TEST POINT TABLE

Test Point	Description
TP-1	Tach Feedback Reference Voltage (8V _{DC} / Max. Speed)
TP-2	Arm Feedback Reference Voltage (7.5V _{DC} / Max. Speed)
TP-4	Accel & Decel Voltage Ramp (+8 V _{DC} / Max.)
TP-5	ASR Voltage (+4 V _{DC} / Rated Current)
TP-6	ACR Voltage (-8 V _{DC} / Max.)
TP-7	Field Current Reference Voltage (2V _{DC} / Max. IF)
TP-8	Field Current Reference (-7.9 ~ -1.3V _{DC})
TP-9	Reference Input for Fire Block Test (factory use only)
TP-10	Armature Current Oscilloscope Connection Point
15	+15 Volt Power Supply (±0.5 V)
-15	-15 Volt Power Supply (±0.5 V)
+V	Internal Relay Power (19.5 V _{DC} ±1V)
+B	External Relay Signal Voltage (20 V _{DC} ±1V)

Statohm IV DC Drive Common Specifications

Input Power	3 Phase Input Voltage	230V _{AC} or 380V _{AC} or 460V _{AC} or 600V _{AC} , Nominal range $\pm 10\%$
	1 Phase Input Voltage	115V _{AC} or 230V _{AC}
	Input Frequency	50 Hz and 60 Hz
Output Power	Armature Starting & Starting Regenerating Current	Adjustable up to 200% for up to one minute.
	Field	1 phase, SCR phase control, Current Regulation Circuit 0.8A ~ 30A.
	Field Economy	When stopped the field is reduced to 50%, this feature can be disabled.
	Field Weakening	Only for motors with DC tachometers. The field can be reduce down to $\frac{1}{3}$ of full field Crossover voltage can be adjusted down to $\frac{3}{5}$ of full armature voltage. Notes: Field Weakening is used to extend speed and / or adjust torque. The crossover voltage is the armature voltage when field weakening begins.
Motor Regulation Features	Speed Regulation	Armature feedback regulation $\pm 2\%$, Ratio 1:100 DC tachometer feedback regulation $\pm 0.5\%$, Ratio 1:100 DC tachometers from 18V/1000RPM up to 100V/1000RPM
	Acceleration & Deceleration	0.7 to 120 seconds, each independently adjustable.
	Braking (12 SCR drives only)	Regenerates power to lines
	Current Limit	Adjustable up to 150%. 12 SCR drives have independent forward and reverse current limits.
	Control Input & Output Features	Speed Reference
Reverse (12 SCR drives only)	Reverse Terminal	V _{REF} Speed Reference Polarity, ± 8 V and ± 10 V, Aux Power Supply Required
Jog	0 ~ 20% of maximum speed, independent acceleration adjustment	
Emergency Stop (E. Stop)	Controlled deceleration or coast to stop.	
PC (i.e. Enable)	Safety feature to detect Pre-operation Conditions are met before the drive is enabled to start.	
Zero speed Detect relay	ZD relay has adjustable trip voltage. SPDT 0.5A / 250V _{AC}	
Fault Trip relay	FT relay, SPDT 0.5A / 250V _{AC}	
Field Loss relay	FL relay, SPDT 0.5A / 250V _{AC}	
Armature Ammeter output	0 ~ 2V	
Field Ammeter output	0 ~ 2V	
Speed Meter output	0 ~ 1mA	
Master Slave operation	One master drive and one slave drive One master drive and one slave drive with master speed gain	
Fault Diagnosis and Protection	Instantaneous Overload Trip (OC)	ST overload relay (i.e. Shunt Trip) is triggered at 250%, SPDT 0.5A / 250V _{AC}
	One Minute Delay Over Current (OL)	150% of the motors' rating exceeded for more than one minute.
	High / Low Input Voltage (LVL)	$\pm 15\%$ of input voltage.
	Phase Error (PH)	Detects phase sequence error or phase lost.
	Tachometer Generator Loss (TG)	User has choice of stop or full speed when TG loss is detected.
	Field Loss (FL)	Detects when field current is 13% below normal.
	SCR Thyristor Over Heat (OH)	85°C / 185°F thermostat switches off motor.
	Fuse Blown (FU)	Signal light indicates when AC input fuse has blown.
Environment	Storage Temperature	-40° F to +140° F / -40° C to +60° C
	Ambient Operating Temperature	-14° F to +104° F / -10° C to +40° C
	Relative Humidity	95% max., no condensation allowed
	Atmosphere	Avoid iron dust particles and corrosive gases , example: Ocean air.
	Ventilation	Mount lengthwise vertical position, 5"/125 mm air space on all sides and 2"/50 mm air space on front side in ventilated enclosure.

Model Ampere and Power Ratings

Model Number	42NS1-*	42RS1-*	42NS2-*	42RS2-*	42NS3-*	42RS3-*	42NS4-*	42RS4-*	42NM2-*	42RM2-*	42NM3-*	42RM3-*	42NL1-*	42RL1-*	42NL2-*	42RL2-*	42XXNL4*	42XXNL5*	42XXNL7*
Max., Current	37A	70A	110A	180A	400A	550A	720A	910A	1,100A	1,400A	1,800A	Above 1000 HP inquire							
Input 208~240V, Arm 240V	7 HP	15 HP	25 HP	45 HP	100 HP	125 HP	200 HP	250 HP	300 HP	---	---								
Input 380~410V, Arm 440V	3 kW	20 kW	32 kW	58 kW	130 kW	165 kW	233 kW	375 kW	---	---	---								
Input 440~480V, Arm 500V	14 HP	30 HP	50 HP	90 HP	200 HP	250 HP	400 HP	500 HP	600 HP	750 HP	1,000 HP								
Input 575~600V, Arm 600V	---	36 HP	60 HP	108 HP	240 HP	300 HP	480 HP	600 HP	720 HP	900 HP	1,200 HP								

Alphabetical Index

1 Jumper (JP-1)	Pg. 9	Section 4.7
10 Jumper (JP-10)	Pg. 49	Jumper Table
1058C Synchronization Card	Pg. 39	
1059A Regulator Card Physical Diagram	Pg. 48	
2 Jumper (JP-2)	Pg. 13, Sec 4.14 and Pg. 49	
2 Quadrant, 6 SCR Elementary Diagram	Pg. 54	
3 Jumper (JP-3)	Pg. 13, Sec 4.14 and Pg. 49	
4 Jumper (JP-4)	Pg. 49	Jumper Table
4 Quadrant, 12 SCR Elementary Diagram	Pg. 54	
5 Jumper (JP-5)	Pg. 49	Jumper Table
50H Jumper	Pg. 49	Jumper Table
6 Jumper (JP-6)	Pg. 49	Jumper Table
7 Jumper (JP-7)	Pg. 5, Sec 3.5 and Pg. 18, Sec 5.11A	
8 Jumper (JP-8)	Pg. 5, Sec 3.5 and Pg. 18, Sec 5.11A	
9 Jumper (JP-9)	Pg. 49	Jumper Table
9042-1 Regulator Card Block Diagram	Pg. 43	
9042-2 Regulator Card Block Diagram	Pg. 44	
9042-3 Regulator Card Block Diagram	Pg. 45	
9044 Regulator Card Control Block Diagram	Pg. 42	
A1~A4 Jumpers	Pg. 5, Sec 3.2 and Pg. 8, Sec 4.4	
AC contactor	Pg 23	Section 5.18
AC Power Connections	Pg. 7	Section 4.1
ACC Potentiometer	Pg. 20	Section 5.13
Acceleration and Deceleration Time Range Jumpers	Pg. 5	Section 3.6
AM Potentiometer	Pg. 13	Section 4.14
AP Jumper	Pg. 49	Jumper Table
Armature Ammeter Wiring and Calibration	Pg. 13	Section 4.14
Armature and Field in series (see field disable)	Pg. 18	Section 5.11C
Armature Connections	Pg. 7	Section 4.4
Armature Current Calibration	Pg. 19	Section 5.12
Armature Current is too high at low speed and normal load.	Pg. 32	Section 6.12
Armature Current Jumpers	Pg. 5	Section 3.2
Armature Current Limit Adjustment	Pg. 19	Section 5.12A
Armature Feedback Jumper Settings	Pg. 5	
Armature Feedback Jumper Settings	Pg. 4	
Armature Voltage Adjustment	Pg. 19	Section 5.12
ASR Feedback Loop Adjustment (i.e. Speed PID)	Pg. 21	Section 5.15
Balancing Phase Load	Pg. 25	Section 6.1
CA Jumper	Pg. 18	Sections 5.11A
Check prior to operation	Pg. 15	Section 5.1
CROS Potentiometer	Pg. 18, Sec 5.11A & Pg. 19, Sec 5.12	
Current Gain Loop Adjustment (i.e. Current PID)	Pg. 21	Section 5.16
Current Limit Adjustment	Pg. 19	Section 5.12A
DC Contactor	Pg. 23	Section 5.19
DC Tach Generator Feedback	Pg. 10	Section 4.11
DC Tach Voltage Jumpers	Pg. 5	Section 3.4
DEC Potentiometer	Pg. 20	Section 5.13
Deceleration and Acceleration Time Range Jumpers	Pg. 5	Section 3.6
DG Potentiometer	Pg. 49	Potentiometer Table
EF Jumper	Pg. 16	Section 5.5
Elementary Circuit Diagrams	Pg. 54	
Elementary Diagram of DC Drive Power Connections	Pg. 6	
Emergency Stop (E.Stop)	Pg. 10	Section 4.10
Emergency Stop (E. Stop)	Pg. 16	Section 5.5
Environment, Operation	Pg. 3	Section 2.1
ES light (Emergency Stop)	Pg 25 and Pg. 49,	Section 5.11B

Alphabetical Index Continued

Field Ammeter Wiring and Calibration	Pg. 14	Section 4.15
Field Amperage Adjustment	Pg. 18	Section 5.11
Field and Armature in Series (see field disable)	Pg. 18	Section 5.11C
Field Connections	Pg. 8	Section 4.5
Field Current Jumpers	Pg. 5	Section 3.1
Field Disable	Pg. 18	Section 5.11C
Field Economy	Pg. 18	Section 5.11B
Field Loss	Pg. 18	Section 5.11E
Field Loss is Detected.	Pg. 31	Section 6.11
Field Overview	Pg. 18	Section 5.11
Field Regulation Jumpers	Pg. 5	Section 3.5
Field Weakening Adjustment (Tach Feedback Only)	Pg. 18	Section 5.11A
FL Jumper	Pg. 18	Sections 5.11C & 5.11E
FL light	Pg. 25, Pg. 33	Section 6.14 and Pg. 49
FL Potentiometer	Pg. 19	Section 5.12A
FM Potentiometer	Pg. 14	Section 4.15
Forward and Reverse Current Limit Adjustment	Pg. 19	Section 5.12B
FT Potentiometer	Pg. 15, Sec 5.4 and Pg. 16, Sec 5.5	
FU light	Pg. 25 and Pg. 49	
Fuse Replacement	Pg. 7	Section 4.3A
Fuses blow immediately after start and the “OC signal lights	Pg. 28	Section 6.4
FV Jumper	Pg. 14	Section 4.15
Grounding	Pg. 7	Section 4.2
Horsepower Rating	Pg. 3	Section 1.1
HS Potentiometer	Pg. 17	Section 5.8
IA Potentiometer	Pg. 19	Section 5.12C
IF Potentiometer	Pg. 18	Sec 5.11A and Pg. 14 Sec 4.15
IFC 1084 card	Pg. 38	
IFR Jumper	Pg. 49	Jumper Table
IG Potentiometer	Pg. 21	Section 5.16
IMX Potentiometer	Pg. 19	Sections 5.12, 5.12A, 5.12B
Installation Location	Pg. 3	Section 2
Instantaneous Overload Current Shut-off Adjustment	Pg. 19	Section 5.12D
Jog	Pg. 10	Section 4.8
JOG Potentiometer	Pg. 15	Section 5.4
Jog Speed & Acceleration Adjustment	Pg. 15	Section 5.4
Jumper Setting Diagram	Pg. 4	
Jumper Settings	Pg. 5	Section 3
Jumper Table	Pg. 5 and Pg. 49	
L1 Model Physical Diagram	Pg. 37	
L2 Model Physical Diagram	Pg. 37A	
Location, Installation	Pg. 3	Section 2
LV light (i.e. LVL)	Pg. 25 and Pg. 49	
M2 Model Physical Diagram	Pg. 35	
M3 Model Physical Diagram	Pg. 36	
Master Slave Operation	Pg. 22	Section 5.17
MAX Potentiometer	Pg. 18, Sec 5.11A and Pg. 17, Sec 5.9	
Maximum Speed for Armature Feedback Adjustment	Pg. 17	Section 5.9
Maximum Speed for DC Tach Feedback Adjustment	Pg. 17	Section 10
Meter Dimensions	Pg. 11	Section 4.12
Model Number Scheme	Pg. 3	Section 1.1
Motor Data and Elementary Motor Connection Diagram	Pg. 41	
Motor Feedback Jumpers	Pg. 5	Section 3.3
Motor Rotation Detection Relay and Signal Light Adjustment (i.e. ZD)	Pg. 16	Section 5.6
Motor Speed Runaway	Pg. 27	Section 6.3
Motor will not go to full speed	Pg. 30	Section 6.6

Alphabetical Index Continued

Motor information	Pg. 41
Motor connections	Pg. 41
NA Potentiometer	Pg. 12 Section 4.13
OC light	Pg 25 and Pg. 49
OH light	Pg 25 and Pg. 49
OL light	Pg 25 and Pg. 49
One Minute Timed Overload Shut-off Adjustment	Pg. 19 Section 5.12C
OP Potentiometer	Pg. 16 Section 5.5
Operating Environment	Pg. 3 Section 2.1
Operation and Adjustment	Pg. 15 Section 5
Oscilloscope	Pg. 40
Overload "OL" signal light	Pg. 30 Section 6.8
Overshoot and Undershoot	Pg. 30 Section 6.7
Overshoot and Undershoot	Pg. 20 and Pg.30
P1 ~ P6 Potentiometer	Pg. 26 Section 6.1A
PC, Pre-Operational Conditions (i.e. Enable Drive)	Pg. 9 Section 4.6
Permanent Magnet Field	Pg. 8 Section 4.5A
Permanent Magnet Field (see field disable)	Pg. 18 Section 5.11C
PH light (Phase loss or phase sequence error)	Pg 25 , Pg. 33, Pg 33A and Pg. 49
Phase Load Balancing	Pg. 25 Section 6.1
Phase Sequence Test	Pg. 7 Section 4.3
PI Potentiometer	Pg. 21 Section 5.15
PID Current Regulation (i.e. Current Gain Loop Adjustment)	Pg. 21 Section 5.16
PID Speed Regulation (See ASR Feedback Loop Adjustment)	Pg. 21 Section 5.15
Potentiometer Table	Pg. 49
Power and Control Circuit Wiring Introduction	Pg. 7 Section 4
Pre-Operation Voltage Checks	Pg. 15 Section 5.2
-R Potentiometer	Pg. 49 Potentiometer Table
Receiving & Storage	Pg. 3 Section 1
Regenerative 12 SCR Elementary Diagram	Pg. 54
Regulator Card Block Diagram # 9042-1	Pg. 43
Regulator Card Block Diagram # 9042-2	Pg. 44
Regulator Card Block Diagram # 9042-3	Pg. 45
Regulator Card Control Block Diagram # 9044	Pg. 42
Regulator Card Physical Diagram	Pg. 48
Regulator Card Tables (for Pots, Jumpers, Signal Lights and Test Points)	Pg. 49
Reverse Current Limit Adjustment	Pg. 19 Section 5.12B
Reversing 12 SCR Elementary Diagram	Pg. 54
RL Potentiometer	Pg. 19 Section 5.12A
S Model Physical Diagram	Pg. 34
S1 and S2 motor leads	Pg 41
S1~S4 Jumpers	Pg. 5, Sec 3.4 and Pg. 10, Sec 4.11
Series Field and Armature Motors (see field disable)	Pg. 18 Section 5.11C
SF Jumper	Pg. 5, Sec 3.3 and Pg. 17, Sec 5.10
SG Potentiometer	Pg. 20 Section 5.14A
Signal Light Table	Pg. 49
Signal lights R and PC are on F,AP, ZD flash and relays buzz.	Pg. 31 Section 6.10
Slave Master Operation	Pg. 22 Section 5.17
Speed Meter Wiring and Calibration	Pg. 12 Section 4.13
Speed Overshoot Adjustment (i.e. Speed Response)	Pg. 20 Section 5.14A
Speed Overshoot and Stability Adjustment Overview	Pg. 20 Section 5.14
Speed Reference & Reverse	Pg. 9 Section 4.7
Speed Stability Adjustment (i.e. Speed Gain)	Pg. 20 Section 5.14B
SR Potentiometer	Pg. 20 Section 5.14A

Alphabetical Index Continued

Stabilizing field winding	Pg. 32	Section 6.12B and Pg 41
Start & Stop (i.e. Run & Stop)	Pg. 10	Section 4.9
Synchronization Card 1058C	Pg. 39	
T1~T4 Jumpers	Pg. 5, Sec 3.6 and Pg. 10, Sec 4.11	
Tach Feedback Jumper Settings	Pg. 5	Section 3.3
Terminal Table (for Regulator Card)	Pg. 47	
Test Point Table	Pg. 49	
Test Run	Pg. 15	Section 5.3
TG Jumper	Pg. 5	Section 3.3
TG light (i.e. TGL)	Pg. 25 and Pg. 49	
TG Voltage Jumpers	Pg. 4	Section 3.4
The ES, OH, VL signal lights are on and can not be reset	Pg. 31	Section 6.9
TL Jumper	Pg. 5, Sec 3.3 and Pg. 18, Sec 5.11C	
Troubleshooting	Pg. 25	Section 6
Undershoot and Overshoot	Pg. 30	Section 6.7
Unstable Speed	Pg. 29	Section 6.5
VF Jumper	Pg. 5	Section 3.3
Wire Size Tables	Pg. 6	
Wiring	Pg. 7	Section 4
ZD, Zero motor rotation Detection relay and signal light Adjustment	Pg. 16	Section 5.6
ZERO Potentiometer	Pg. 16	Section 5.7
Zero Speed Hysteresis Adjustment (12 SCR Regenerative Drives Only)	Pg. 17	Section 5.8
Zero Speed Adjust (12 SCR Regenerative Drives Only)	Pg. 16	Section 5.7